

## V.32, V.22bis, V.22, V.23, V.21, BELL 212A, BELL 103 MODEM CHIP SET

### ADVANCE DATA

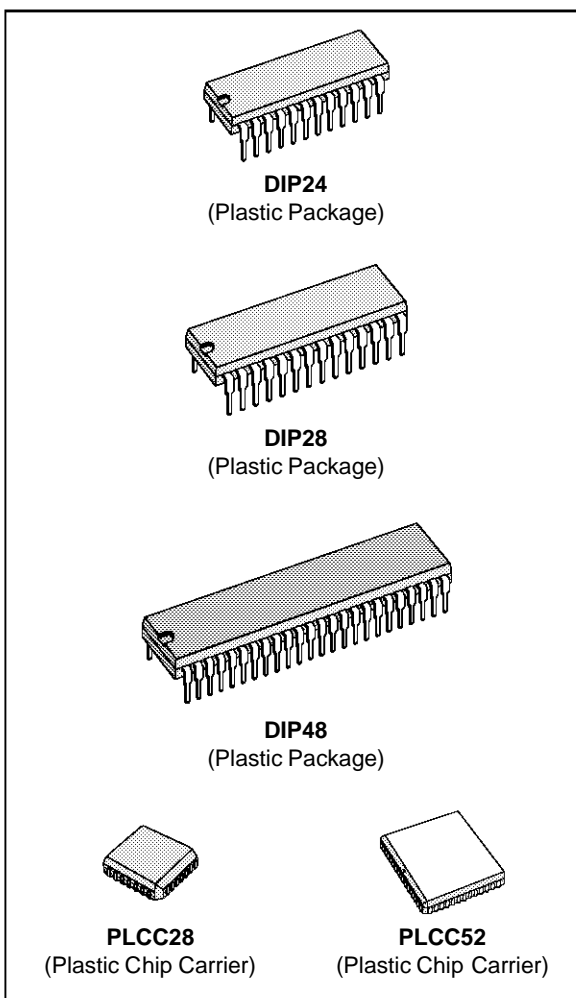
- CCITT V.32, V22bis, V.22, V.21, V.23, Bell 212A, Bell 103 COMPATIBLE MODEM CHIP SET
- INTEGRATED IMPLEMENTATION ON THREE DSP AND THREE MAFE CHIPS
- FULL DUPLEX OPERATION FROM 9600 TO 300BPS
- FULL IMPLEMENTATION OF THE V.32 AND V.22bis HANDSHAKE
- DYNAMIC RANGE : 43dB
- TWO SATELLITE HOPS AND FREQUENCY OFFSET CAPABILITIES (10Hz) FOR THE FAR END ECHO CANCELLER IN V.32 MODE
- TRELLIS ENCODING AND VITERBI DECODING
- 12.5% ROLL-OFF RAISED COSINE TRANSMITTER PULSE SHAPING
- HIGH PERFORMANCE PASSBAND FRATIONALLY SPACED ADAPTIVE EQUALIZER
- SIGNAL QUALITY MONITORING
- PARALLEL INTERFACE TO STANDARD MICROPROCESSORS
- BIT RATE DATA CLOCKS PROVIDED FOR SYNCHRONOUS DATA TRANSFER
- FULL DIAGNOSTIC CAPABILITY
- DTMF GENERATION
- CALL PROGRESS TONE DETECTION
- SOFTWARE LICENSE AND DEVELOPMENT TOOLS AVAILABLE FOR EASY CUSTOMIZATION
- TOTAL POWER CONSUMPTION BELOW 2W

### DESCRIPTION

The SGS-THOMSON Microelectronics TS75C32 chip set is a highly integrated modem engine, which can operate in full duplex from 9600 to 300bps. The modem hardware consists of three analog front end (MAFE) chips, three DSP processor chips and additional memory chips.

The three SGS-THOMSON analog front end chips (TS68950/1/2) are the transmit interface, the receive interface and the clock generator respectively.

The modem signal processing functions are implemented on three ST18930 programmable digital signal processors.



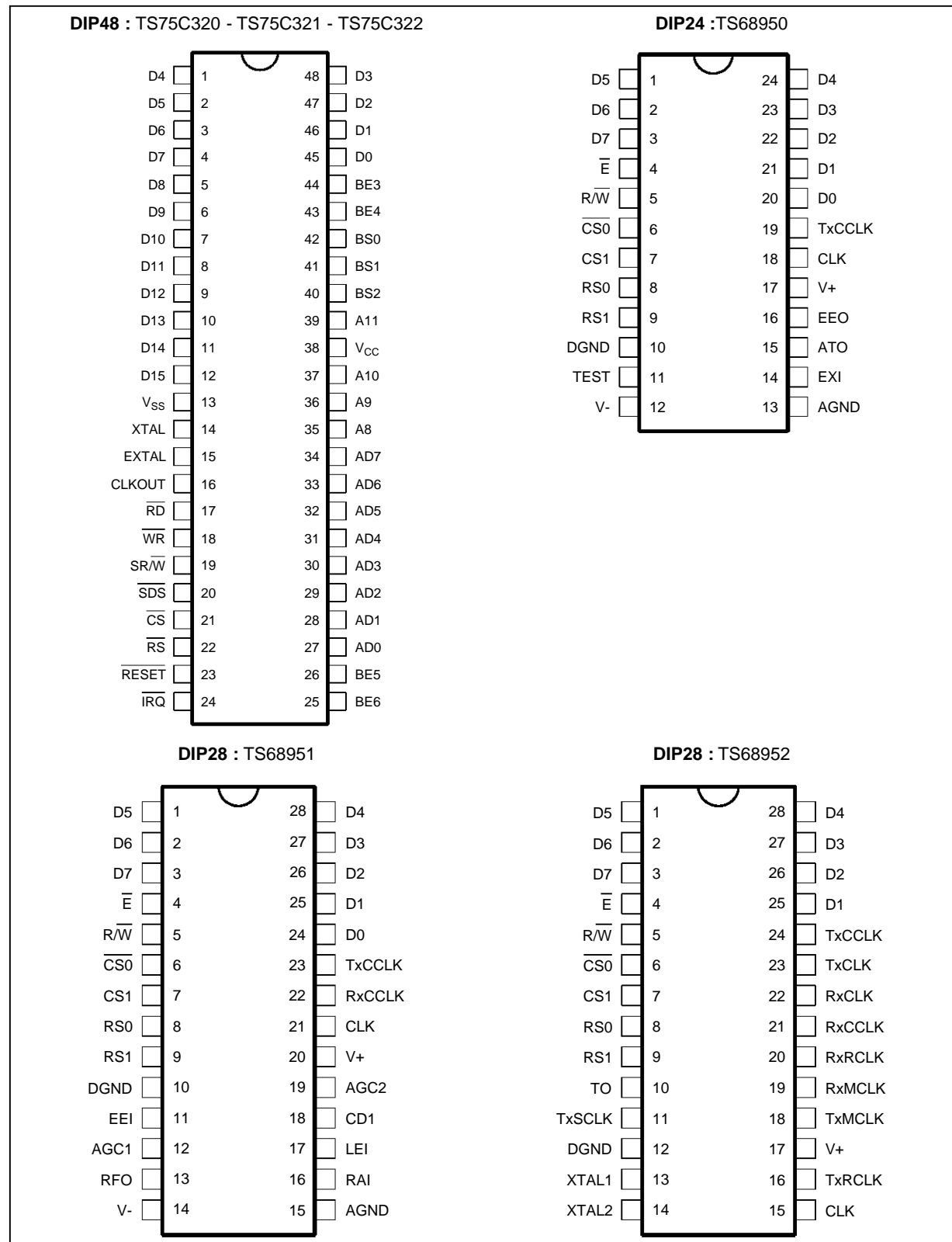
### ORDER CODES

Part Number	Temperature Range	Package
TS75C320CP	0°C to 70°C	DIP48
TS75C321CP	0°C to 70°C	DIP48
TS75C322CP	0°C to 70°C	DIP48
TS68950CP	0°C to 70°C	DIP24
TS68951CP	0°C to 70°C	DIP28
TS68952CP	0°C to 70°C	DIP28
TS75C320CFN	0°C to 70°C	PLCC52
TS75C321CFN	0°C to 70°C	PLCC52
TS75C322CFN	0°C to 70°C	PLCC52
TS68950CFN	0°C to 70°C	PLCC28
TS68951CFN	0°C to 70°C	PLCC28
TS68952CFN	0°C to 70°C	PLCC28

75C32-01.TBL

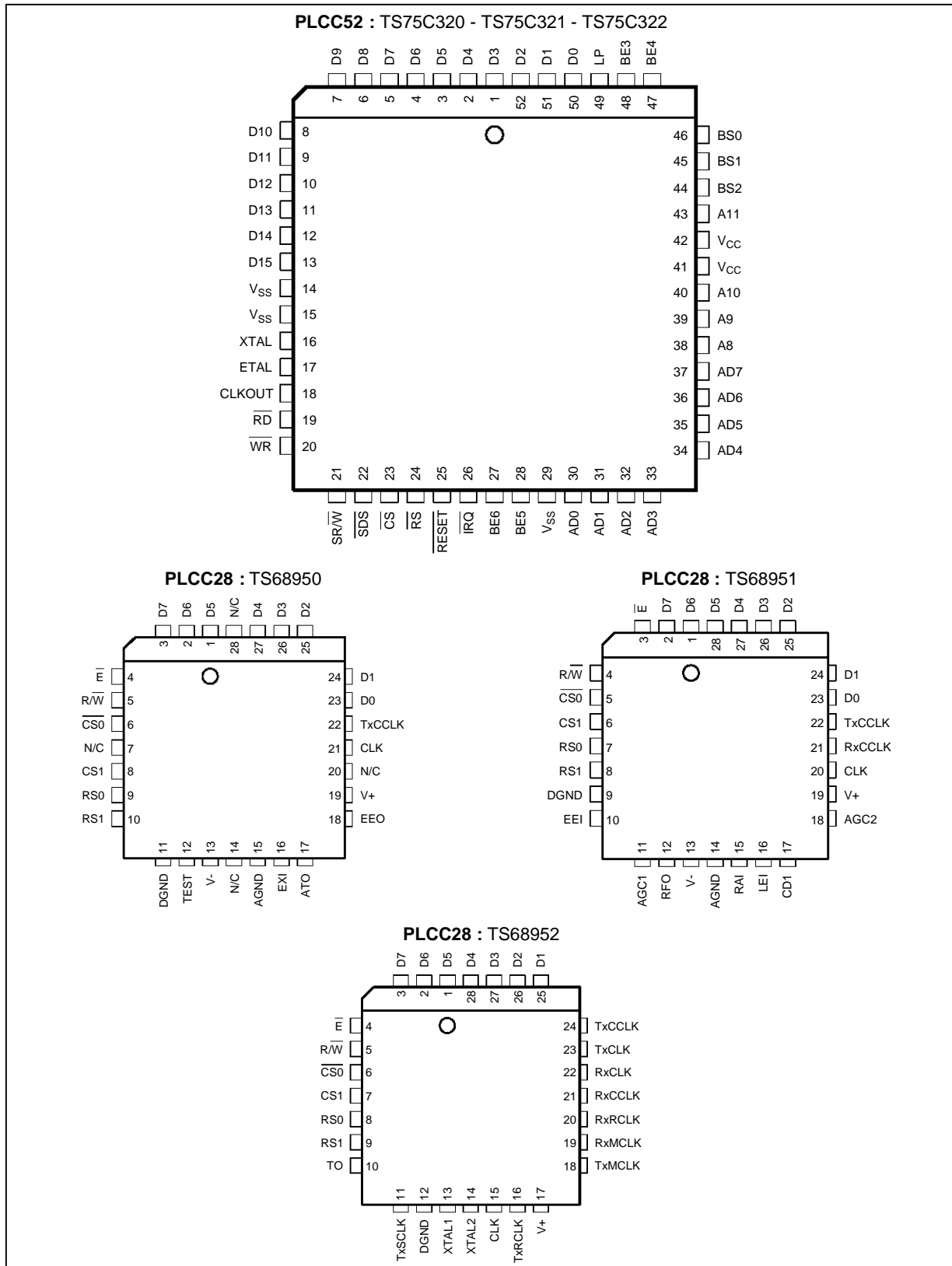
# TS75C32

## PIN CONNECTIONS



75C32-01.EPS / 75C32-02.EPS / 75C32-03.EPS / 75C32-04.EPS

PIN CONNECTIONS



75C32-06.EPS / 75C32-08.EPS / 75C32-07.EPS / 75C32-08.EPS

## TS75C32

### PIN DESCRIPTION

Pin Name	Type	Signal Name	Description
----------	------	-------------	-------------

#### SYSTEM INTERFACE

##### TS75C321 (DSP#1 Transmitter and Handshake)

AD0.AD7	I/O	D0H.D7H	System Data Bus : these lines are used for data transfer between the TS75C32 mailbox and the host processor
$\overline{\text{CS}}$	I	CSL	Chip Select : this input is asserted when the TS75C32 is to be accessed by the host processor
$\overline{\text{RS}}$	I	RSL	Register Select : this signal is used to control the data transfers between the host processor and the TS75C32 mailbox
$\overline{\text{SDS}}$	I	DSL	System Data Strobe : synchronizes the transfer between the TS75C32 mailbox and the host processor
$\overline{\text{SR/W}}$	I	RWL	System Read/Write : control signal for the TS75C32 mailbox operation
$\overline{\text{IRQ}}$	O	INTL	Interrupt Request : signal sent to the host processor to access the TS75C32 mailbox
$\overline{\text{RESET}}$	I	RSTL1	Master Reset of DSP#1

#### ANALOG INTERFACE

##### TS68950 (Analog Front End Transmitter)

ATO	O	ATO	Analog Transmit Output
-----	---	-----	------------------------

##### TS68951 (Analog Front End Receiver)

RAI	I	RAI	Receive Analog Input
LEI	I	LEI	Local Echo Input. Must be grounded.

#### CLOCK INTERFACE

##### TS68952 (Clock Generator)

TxCLK	O	TxCLK	Transmit Bit Clock
TxRCLK	O	TxRCLK	Transmit Baud Clock
TxCCLK	O	TxCCLK	Transmit Conversion Clock
TxMCLK	O	TxMCLK	Transmit Multiplex Clock
RxCLK	O	RxCLK	Receive Bit Clock
RxRCLK	O	RxRCLK	Receive Baud Clock
RxCCLK	O	RxCCLK	Receive Conversion Clock
RxMCLK	O	RxMCLK	Receive Multiplex Clock
TxSCLK	I	TxSCLK	Transmit Synchro Clock : can be used to synchronize the transmitter on an external bit clock provided by the RS232C (or V.24) junction

75C32-02.TBL

**ABSOLUTE MAXIMUM RATINGS**

Symbol	Parameter	Value	Unit
--------	-----------	-------	------

TS75C320/1/2

V <sub>CC</sub> (1)	Supply Voltage	- 0.3, + 7.0	V
V <sub>IN</sub> (1)	Input Voltage	- 0.3, + 7.0	V
T <sub>oper</sub>	Operating Temperature	0, + 70	°C
T <sub>stg</sub>	Storage Temperature	- 55, + 150	°C

TS68950/1/2

	Supply Voltage between V + and AGND or DGND	- 0.3, + 7	V
	Supply Voltage between V - and AGND or DGND	- 7, + 0.3	V
	Voltage between AGND and DGND	- 0.3, + 0.3	V
	Digital Input Voltage	DGND - 0.3, V <sub>CC</sub> <sup>+</sup> + 0.3	V
	Digital Output Voltage	DGND - 0.3, V <sub>CC</sub> <sup>+</sup> + 0.3	V
	Digital Output Current	- 20, + 20	mA
	Analog Input Voltage	V <sub>CC</sub> <sup>-</sup> - 0.3, V <sub>CC</sub> <sup>+</sup> + 0.3	V
	Analog Output Voltage	V <sub>CC</sub> <sup>-</sup> - 0.3, V <sub>CC</sub> <sup>+</sup> + 0.3	V
	Analog Output Current	- 10, + 10	mA
P <sub>tot</sub>	Power Dissipation	500	mW
T <sub>oper</sub>	Operating Temperature	0, + 70	°C
T <sub>stg</sub>	Storage Temperature	- 65, + 150	°C

75C32-03.TBL

- Notes :** 1. With respect to V<sub>SS</sub>.  
 2. Stresses above those hereby listed may cause permanent damage to the device. The ratings are stress ones only and functional operation of the device at these or any conditions beyond those indicated in the operational sections of this specification is not implied. Exposure to maximum rating conditions for extended periods may affect device reliability. Standard MOS circuits handling procedure should be used to avoid possible damage to the device.

**DC ELECTRICAL CHARACTERISTICS (DGND = AGND = 0V)**

Symbol	Parameter	Min.	Typ.	Max.	Unit
--------	-----------	------	------	------	------

DIGITAL SUPPLY (V<sub>CC</sub> = 5.0V ±10%, V<sub>SS</sub> = 0, T<sub>amb</sub> = 0 to +70°C, unless otherwise specified)

V <sub>CC</sub>	Supply Voltage	4.5	5	5.5	V
V <sub>IL</sub>	Input Low Voltage	- 0.3		0.8	V
V <sub>IH</sub>	Input High Voltage	2.4		V <sub>CC</sub>	V
I <sub>i</sub>	Input Extal Current	- 50		+ 50	μA
I <sub>in</sub>	Input Leakage Current	- 10		10	μA
V <sub>OH</sub>	Output High Voltage (I <sub>load</sub> = - 300μA)	2.7			V
V <sub>OL</sub>	Output Low Voltage (I <sub>load</sub> = 3.2mA)			0.5	V
P <sub>D</sub>	Total Power Dissipation		1.5		W
C <sub>in</sub>	Input Capacitance		10		pF
I <sub>TSl</sub>	Three State (off state) Input Current	- 20		- 20	

ANALOG SUPPLY

V <sup>+</sup>	Positive Power Supply	4.75		5.25	V
V <sup>-</sup>	Negative Power Supply	- 5.25		- 4.75	V
I <sup>+</sup>	Positive Supply Current			35	mA
I <sup>-</sup>	Negative Supply Current	- 35			

75C32-04.TBL

**Note :** Case Temperature T<sub>C</sub> must be maintained below 100°C.

**AC ELECTRICAL SPECIFICATIONS**

**CLOCK AND CONTROL PINS TIMING**

( $V_{CC} = 5.0V \pm 10\%$ ,  $T_{amb} = 0$  to  $+70^{\circ}C$ , see Figure 1 - Output Load = 50pF + DC characteristics I load  
Reference levels :  $V_{IL} = 0.8V$ ,  $V_{IH} = 2.4V$ ,  $V_{OL} = 1.4V$ ,  $V_{OH} = 2.4V$  -  $t_r$ ,  $t_f \leq 5ns$  input signal)

Symbol	Parameter	Test Conditions	Min.	Typ.	Max.	Unit
$t_{cex}$	External Clock Cycle Time	$T_C = 4 \times t_{cex}$	40		100	ns
		$T_C = 2 \times t_{cex}$	50		200	ns
		$T_C = t_{cex}$	40		100	ns
$t_{fex}$	External Clock Fall Time				5	ns
$t_{rex}$	External Clock Rise Time				5	ns
$t_{coh}$	EXTAL to CLKOUT High Delay			25		ns
$t_{col}$	EXTAL to CLKOUT Low Delay			25		ns
$t_{cor}$	CLKOUT Rise Time				10	ns
$t_{cof}$	CLKOUT Fall Time				10	ns
$t_{dlc}$	CLKOUT to Control Output Low (INTL)				30	ns
$t_{dhc}$	CLKOUT to Control High (INTL)				30	ns

**TS68952 : CLOCK GENERATOR (see Figure 2)**

(unless otherwise noted, Electrical Characteristics are specified over the operating range.

Typical values are given for  $V^+ = 5.0V$  and  $t_{amb} = 25^{\circ}C$ )

Symbol	Parameter	Test Conditions	Min.	Typ.	Max.	Unit
--------	-----------	-----------------	------	------	------	------

**CRYSTAL OSCILLATOR INTERFACE**

$V_{IL}$	Input Low Level Voltage				1.5	V
$V_{IH}$	Input High Level Voltage		3.5			V
$I_{IL}$	Input Low Level Current	$DGND \leq V_I \leq V_{IL\ max}$	-15			$\mu A$
$I_{IH}$	Input High Level Current	$V_{IH\ min} \leq V_I \leq V^+$			15	$\mu A$

**CLOCK WAVEFORMS**

PC	Main Clock Period	XTAL1 Input	150	173.6		ns
$t_{wCL}$	Main Clock Low Level Width	XTAL1 Input	50			ns
$t_{wCH}$	Main Clock High Level Width	XTAL1 Input	50			ns
$t_{rC}$	Main Clock Rise Time	XTAL1 Input			50	ns
$t_{fC}$	Main Clock Fall Time	XTAL1 Input			50	ns
$t_{dC}$	Clock Output Delay Time	All Clock Outputs $C_L = 50pF$			500	ns
$t_{tC}$	Clock Output Transition Time	All Clock Outputs $C_L = 50pF$			100	ns

75C32-05.TBL

Figure 1 : Clock and Control Pins Timing

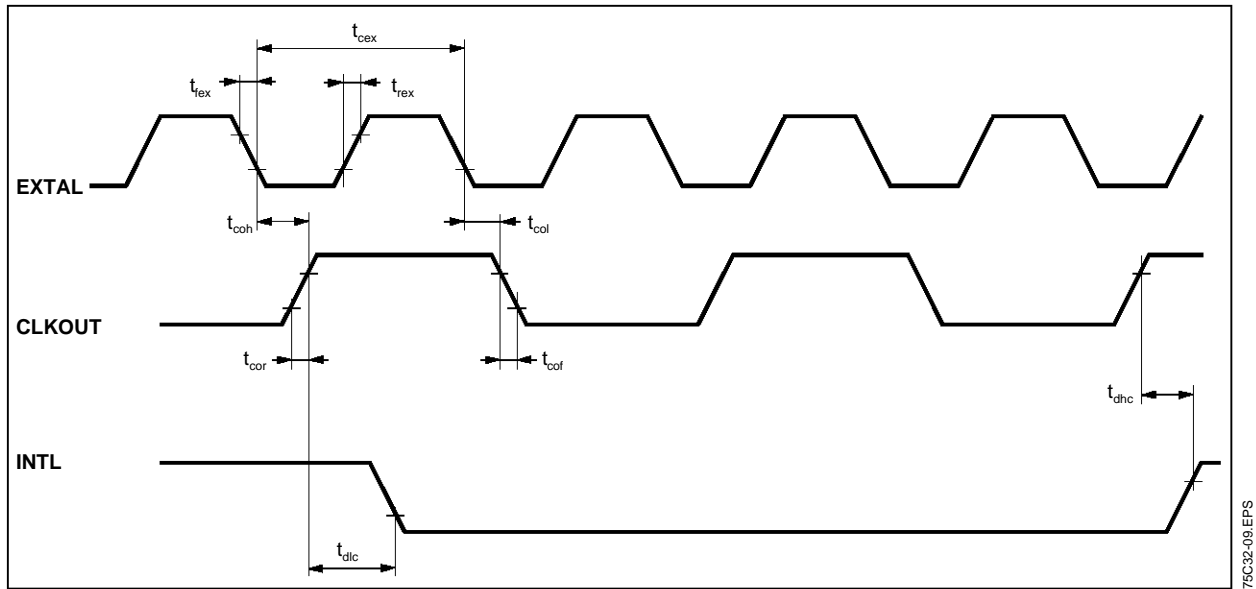
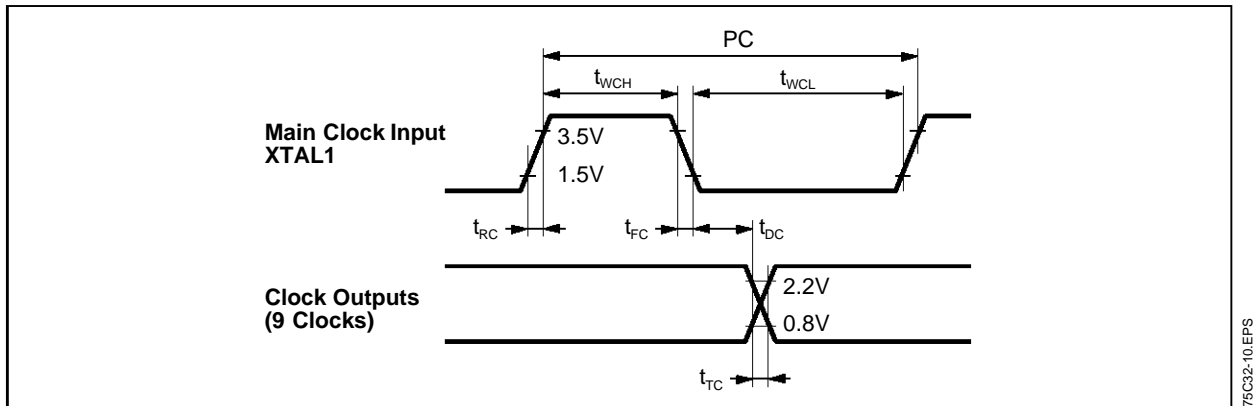


Figure 2 : Clock Generator



## TS75C32

### AC ELECTRICAL SPECIFICATIONS (continued)

LOCAL BUS TIMING ( $V_{CC} = 5.0V \pm 10\%$ ,  $T_{amb} = 0$  to  $+70^{\circ}C$ , see Figure 3)

Symbol	Parameter	Min.	Typ.	Max.	Unit
$t_{PW}$	$\overline{RD}$ , $\overline{WR}$ , $\overline{SOS}$ Pulse Width	$1/2 t_c - 10$		$1/2 t_c$	ns
$t_{AH}$	Address Hold Time	10			ns
$t_{DSW}$	Data Set-up Time, Write Cycle	25			ns
$t_{DHW}$	Data Hold Time, Write Cycle	10			ns
$t_{DZW}$	$\overline{DS}$ High to Data High Impedance, Write Cycle			40	ns
$t_{DSR}$	Data Set-up Time, Read Cycle	20			ns
$t_{DHR}$	Data Hold Time, Read Cycle	5			ns
$t_{ARW}$	Address Valid to $\overline{WR}$ , $\overline{DS}$ , $\overline{SOS}$ Low	$1/2 t_c - 25$			ns

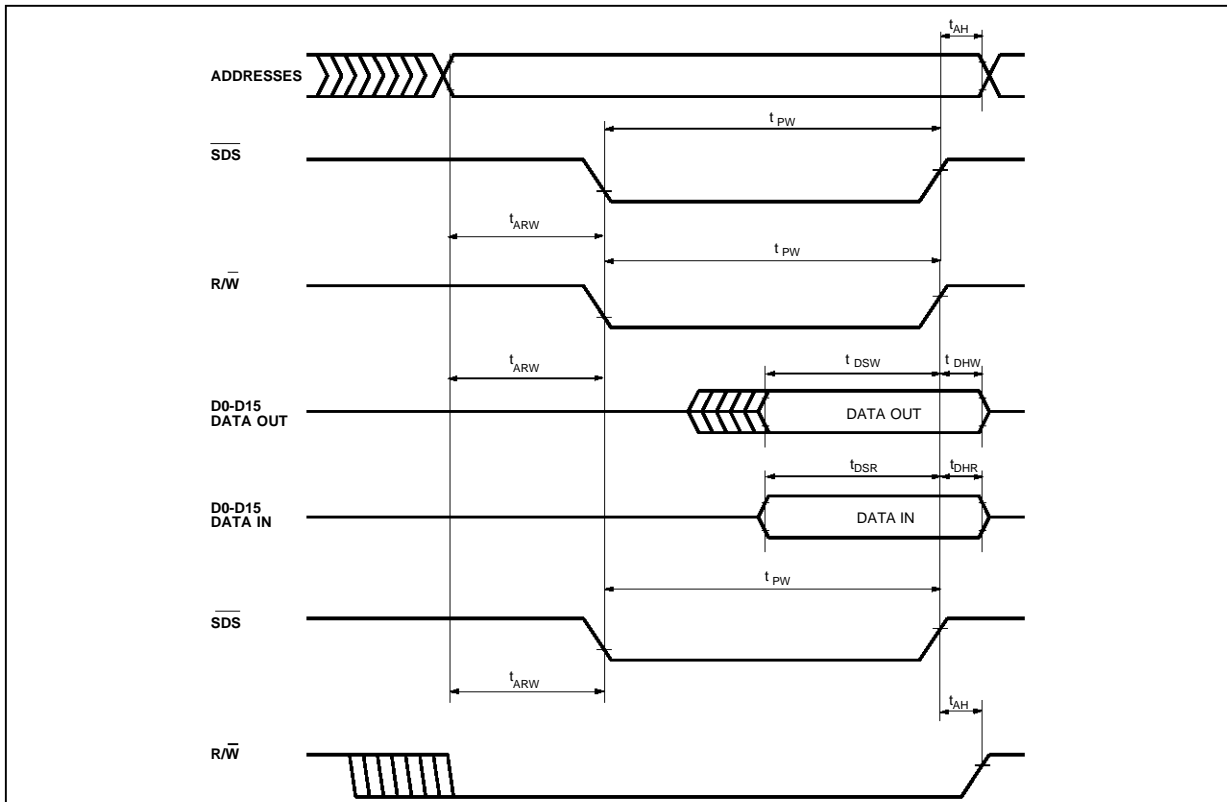
SYSTEM BUS TIMING ( $V_{CC} = 5.0V \pm 10\%$ ,  $T_{amb} = 0$  to  $+70^{\circ}C$ , see Figure 4)

Symbol	Parameter	Min.	Typ.	Max.	Unit
$t_{SPW}$	$\overline{SDS}$ Pulse Width	50			ns
$t_{SAW}$	$\overline{SR}$ / $\overline{W}$ , $\overline{CS}$ , $\overline{RS}$ Set-up Time	15			ns
$t_{SAH}$	$\overline{SR}$ / $\overline{W}$ , $\overline{CS}$ , $\overline{RS}$ Hold After $\overline{SDS}$ High	5			ns
$t_{SDSR}$	Data Set-up Time, Read Cycle	15			ns
$t_{SDHR}$	Data Hold Time, Read Cycle	5			ns
$t_{SDSW}$	Data Set-up Time, Write Cycle			30	ns
$t_{SDHW}$	Data Hold Time, Write Cycle	10		50	ns
$t_{SDHIR}$	$\overline{SDS}$ High to $\overline{IRQ}$ High			800	ns

75C32-06.TBL

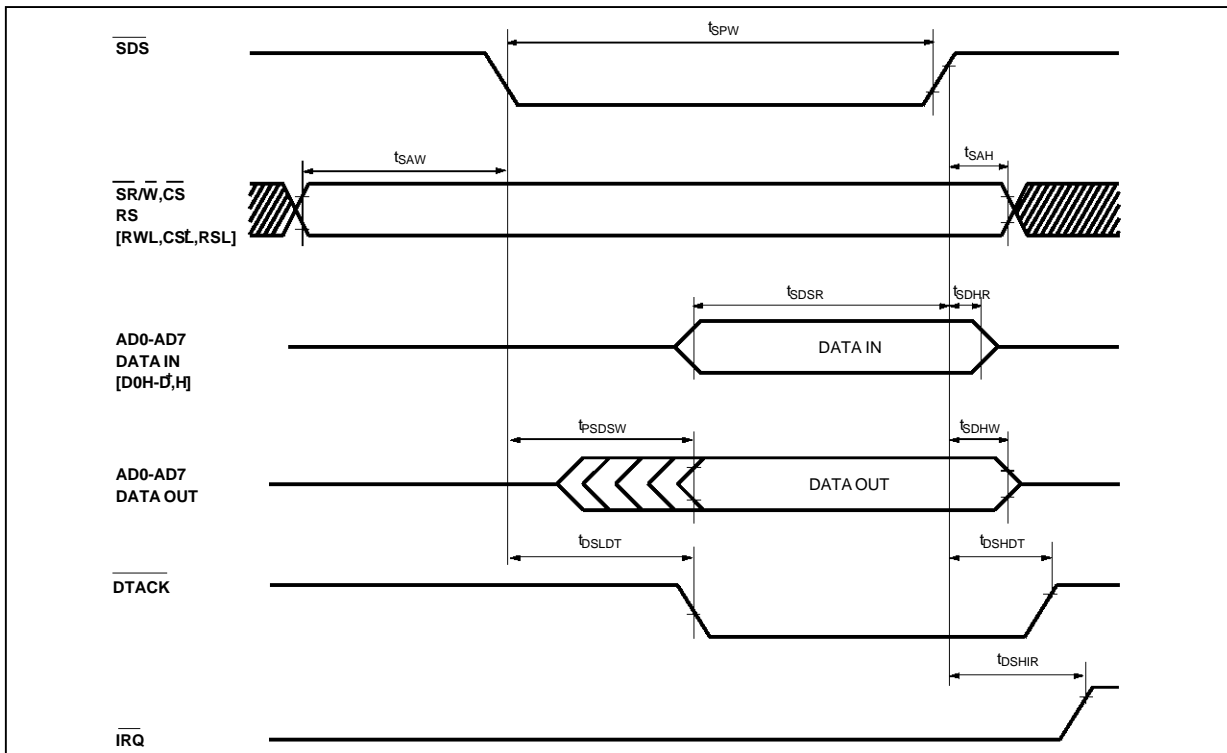


Figure 3 : Local Bus Timing Diagram



75C32-11.EPS

Figure 4 : System Bus Timing Diagram



75C32-12.EPS

**FUNCTIONAL DESCRIPTION**

**1 - SYSTEM ARCHITECTURE**

The SGS-THOMSON TS75C32 chip set is a highly integrated modem engine which provides the functionality and performance requirements for full-duplex 9600bps modem solutions at a low cost and with a small circuit area. At the heart of the modem engine are three SGS-THOMSON DSPs which implement the complete signal processing and control functions. The analog front end of the modem engine consists of the SGS-THOMSON MAFE three-chip set which is designed to meet the requirements of high-speed modem applications and particularly V.32 modems. The only other components in the modem engine are the external RAM chips used for the far-end echo canceller delay line and the Viterbi decoder.

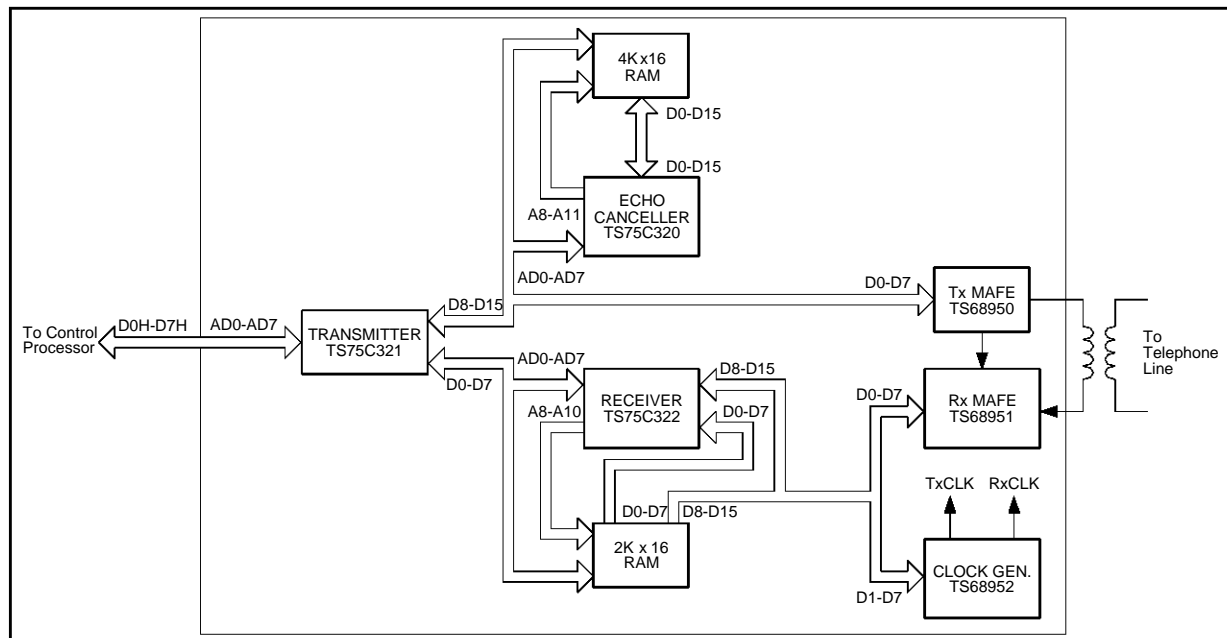
connected to the two other DSPs through its D0-D7 and D8-D15 data buses to transfer data, to pass a control command to the DSPs and to get the modem operation status and then pass it to the control processor. The transmitter, V.32 handshake and part of the receiver algorithms are implemented in this processor. DSP 0 implements the echo cancellation function. 4K x 16 of RAM are connected to this processor to implement the data delay line for the far end echo cancellation. DSP 2 implements most of the receiver functions. 2K x 16 of RAM are attached to it due to the requirements of the Viterbi decoder.

**2 - PROCESSOR AND MAFE CHIPS ARRANGEMENT**

Figure 5 shows the interconnections between the MAFE and signal processors. DSP 1 communicates with the control processor through its system bus, AD0-AD7. It is also con-

The transmitter interface chip, TS68950 (see ref 5 of Appendix D), is connected to the 8 MSB's of the DSP 1 data bus. The echo replica is sent from DSP1 to TS68950 then to the receiver interface chip, TS68951 (see ref 6 of Appendix D), after conversion to analog format. This chip and the clock generator chip, TS68952 (see ref 7 of Appendix D), are connected to the 8 MSB's of the DSP 2 data bus. The clock generator chip generates the A/D and D/A sampling clocks and the data bit and baud rate clocks.

**Figure 5 : Hardware Architecture**



75C32-18.EPS

**FUNCTIONAL DESCRIPTION (continued)**

**3 - OPERATION**

**3.1 - Modes**

The modem implementation is fully compatible with many CCITT and Bell recommendation. It operates at different bit rates from 9600 to 300bps. In the 9600bps mode, the trellis encoder and the Viterbi decoder can be switched in or out. Both the bit rate and trellis options are determined during the initial modem handshake sequence.

During FSK Modes (Bell 103, V.21 and V.23) a byte of information is exchanged with the Data Pump. This byte is a sampling image (7.2kHz) of the Transmit circuit (TxD) of the junction.

**3.2 - Signal Spectrum Shaping**

A square root of 12.5 percent roll-off raised cosine filter is implemented in the transmitter to properly shape the transmit signal pulse. This filter is chosen based on a compromise of two considerations. First, the signal should have a narrow spectrum to avoid severe distortion on the telephone line.

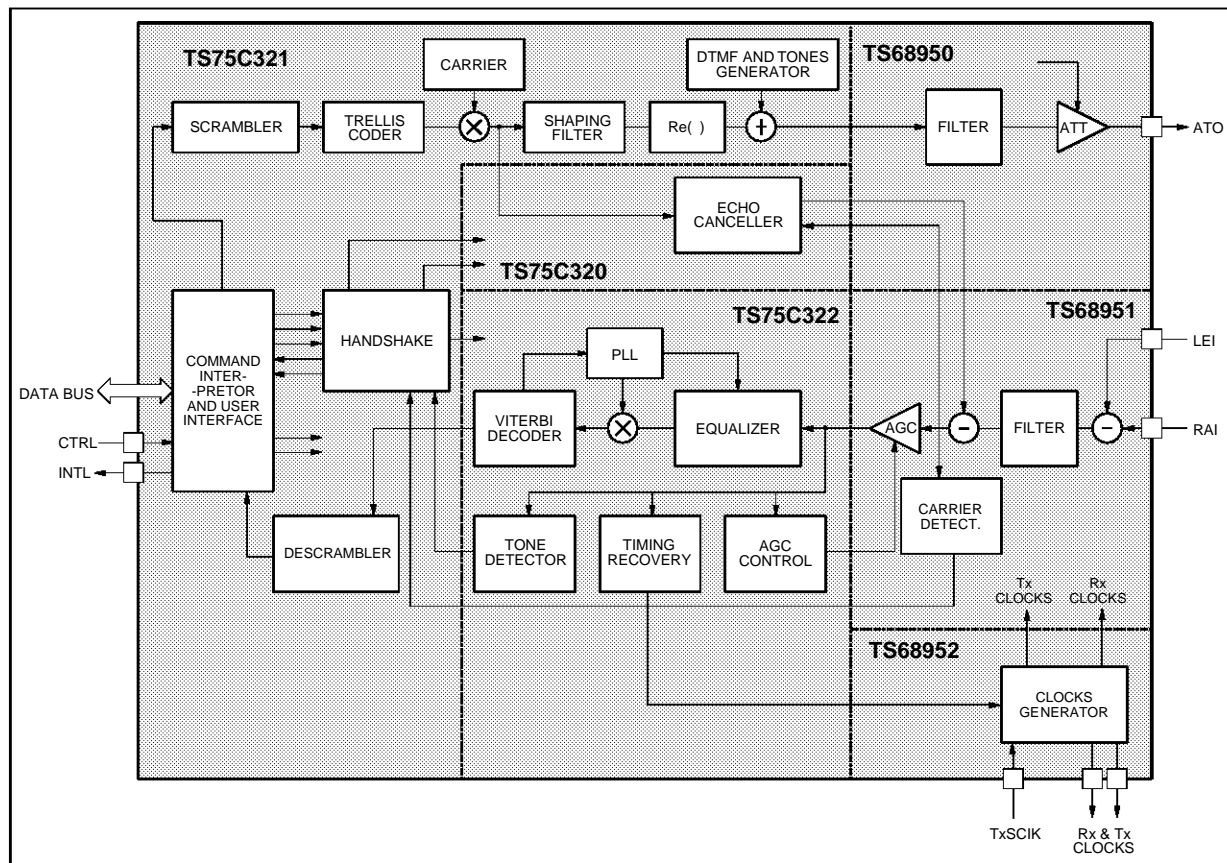
Second, the signal spectrum should be made as wide as possible to facilitate timing recovery in receiver.

**3.3 - Echo Cancellation**

The echo canceller is implemented on a single DSP (see ref 8 of Appendix D) with its associated external RAM. It cancels both near-end and far-end echoes even in the presence of frequency offset in the far-end echo path. The near-end echo cancellation is better than 55dB and the residual near-end echo is smaller than - 65dBm with a near-end echo level of - 10dBm at the receiver input and a far-end signal level of - 43dBm.

The combined near-end and far-end echo cancellers maintain the residual echo level 24dB below the received signal even if the far-end echo signal path introduces up to 10Hz of frequency offset. This level of cancellation is achieved when the far-end echo is 8dB below the received far-end signal.

**Figure 6 : Functional Block Diagram (V.32 Operation)**



75C32-14.EPS

**FUNCTIONAL DESCRIPTION** (continued)

**3.4 - Receiver Description**

The incoming signal is sent to the receiver interface chip to have the echo removed before being sent to DSP 2. The timing recovery algorithm takes the signal after the echo cancellation to derive the timing error to control the sampling phase of the A/D. It is able to cope with distant modem frequency drifts up to  $\pm 2.10^{-4}$  as per CCITT rec. The A/D output samples are sent to the adaptive equalizer and the signal energy estimator for the gain control. The adaptive equalizer outputs a complex number every baud interval, which is then phase corrected by the carrier recovery loop. The Viterbi decoder makes hard decisions on the phase corrected samples for the adaptation of the equalizer and carrier recovery. It also makes soft decisions with an optimum decoding depth.

**3.5 - Equalization**

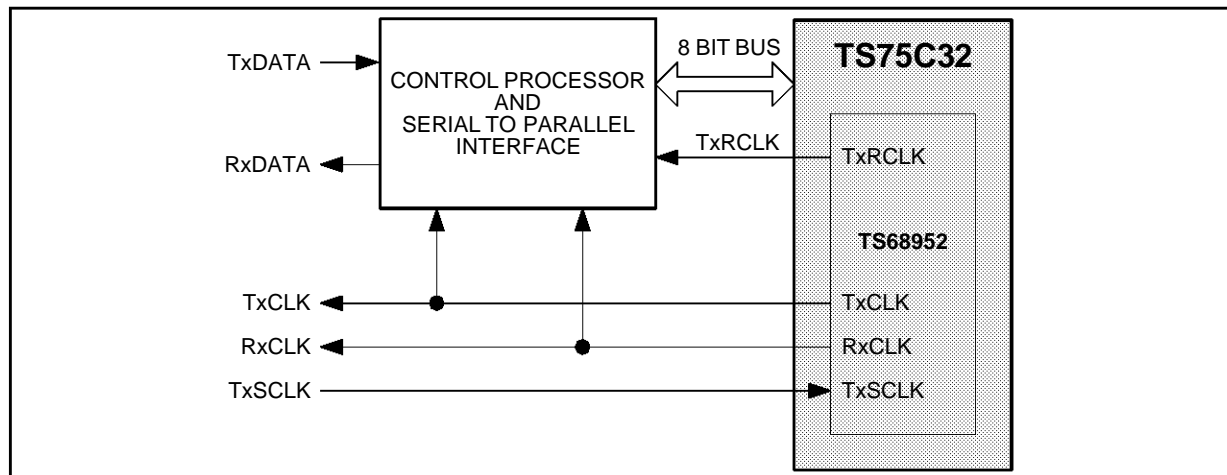
The modem receiver has a passband T/3 fraction-

ally spaced automatic adaptive equalizer which can compensate for the signal degradation caused by low quality line conditions.

**3.6 - Synchronous and Asynchronous Data Transfer**

The TS75C32 modem engine provides the control processor and the DTE with both the transmit and the receive bit clocks (Figure 7). These clocks are generated by the TS68952 and are independent of each other. The receive clock (RxCLK) is derived from the received data signal. The transmit clock (TxCLK) is free-running at the nominal bit rate except during Digital Loopback Mode when it is synchronous to the RxCLK. If the transmit clock is free-running and an external bit clock signal from the terminal is connected to point TxSCLK then the transmit bit clock will be synchronized to that signal. The baud clocks (TxRCLK and RxRCLK) are also available to the control processor. If the TxSCLK pin is not used, it should be tied to a fixed logic level.

**Figure 7 : Clock Signals for Synchronous Transmission**



75C32-15.EPS

## FUNCTIONAL DESCRIPTION (continued)

The control processor interface is synchronous with the transmit baud clock. Eight bits of data are transferred from the control processor to DSP 1 for each information exchange. At 9600bps, the data is transmitted every 2 bauds and the data is transmitted every 4 bauds for 4800bps. The received bits are also nominally transferred from DSP 1 to the control processor once every two transmit baud intervals. When the transmitter is not synchronized with the receiver, however, the receive baud interval may be slightly shorter or longer than the transmit baud interval. If it is shorter, it is necessary to periodically pass 16 received bits from DSP 1 to the control processor. If it is longer, then periodically, there will be no data transmitted from DSP 1 to the control processor. Since the received bits are being passed to the DTE at a fixed rate equal to the RxCLK, some buffering is necessary in the control processor.

For asynchronous transmission, the clocks are not required by the DTE. But since the control processor to DSP 1 interface is still synchronous with respect to the transmit baud clock, the control processor must implement the asynchronous to synchronous conversion (as specified in the V.22 bis recommendation, for example). This will consist of inserting or deleting stop bits as required, to ensure that the transmitted bit rate is within 0.01% of the nominal rate (9600 or 4800bps).

### 3.7 - Clock and Data Synchronization

Both transmit and receive clocks have the same nominal frequency value. However, except in FSK Modes, these clocks are plesiochronous. The nominal frequencies are :

Mode	TxCLK	TxRCLK	Byte/Irq	Rate
V.32TCM	9.6K	2.4K	1/2	9600bps Trellis
V.32QAM	9.6K	2.4K	1/2	9600bps QAM
V.32QAM	4.8K	2.4K	1/4	4800bps
V.22Bis	2.4K	600	1/8	2400bps
V.22	1.2	600	1/16	1200bps
V.22	600	600	1/32	600bps
Bell212A	1.2	600	1/16	1200bps
V.23	7.2K	1.2K	1/3	1200/75bps
Bell103	7.2K	1.2K	1/3	300bps
V.21	7.2K	1.2K	1/3	300bps

The TxCLK is always 7.2kHz. The TxMCLK is always set to 2.4kHz after a configuration command (**cv32**, **cv22b**...), but can be changed by a **cmafe** command.

During the Handshake (V.32 and V.22bis) the bit clock (TxCLK and RxCLK) is set to the maximum value (respectively 9600Hz and 2400Hz). At the

end of the handshake, depending of the negotiation, this frequency is automatically set to the proper value.

The Irq Rate is always 2400 interruptions by second. The Byte/Irq is the nominal ratio of number of Byte of information (data) for each Irq generated by the data pump. The 1/2 ratio means that we have to send (**xmiti** command) 1 byte of data each two Irq, the additional Irq can be used to send an extra CCI command or must be a **nop** command.

### 3.8 - Tone Generator

The TS75C32 Engine has thirteen tone commands to quickly program the tone generators to generate the 2100Hz Answer Tone (ANSWR) and the tone pairs for DTMF digits (DTMF0, ..., DTMF9, DTMF\*, DTMF#). Silence, i.e. termination of tone generation, is accomplished by the use of a fourteenth command, SLNTS. These commands provide the tones and control required for normal operation of the modem.

Some circumstances might arise where additional tones are desired. For such cases, the V.32 Engine provides the user with the ability to generate such additional tones. This special feature is achieved through use of the tone control commands.

The TS75C32 Engine maintains a pair of locations which are reserved for tone generation parameters. These locations are denoted as TONE1 and TONE2. These locations may be programmed by the use of the define tone commands, DEFT1 and DEFT2. These commands provide the two tone generators with the phase increment of the tone to be generated with respect to the 7200Hz sample rate.

The normal tone commands automatically program the tone generators. The DEFT1 and DEFT2 commands do not change the enabled or disabled state of the tone generators. If a tone is being generated when the DEFT command is received, the new tone will be generated without further action on the part of the user. If tone generation was not in progress it is not started.

Enabling the tone generators is accomplished by the tone control commands TGEN0, TGEN1, TGEN2, and TGEN12. Each of these commands affects both tone generators. TGEN0 disables both tone generators and TGEN12 enables both tone generators. To enable tone generator 1 and disable tone generator 2 the TGEN1 command is used. For the reverse condition, with generator 1 disabled and generator 2 enabled, the TGEN2 command is employed.

**FUNCTIONAL DESCRIPTION (continued)**

Refer to the command in appendix A for more detailed information.

Generation of special user tones is not part of the normal data communications operations of the modem. Use of this feature may interfere with data transfer operations. It is the responsibility of the user to insure that the tone generators are used at a time when such interference will not occur and to disable both tone generators when the tone generation operations have been completed.

**3.9 - Test Modes**

The modem can be configured in two test modes, namely analog loop back and digital loop back modes. These loop back modes conform to the test loops 3 and 2 respectively defined in CCITT recommendation V.54.

In the local analog loop back mode, the transmitter signal is directly fed back into the local receiver input with the echo canceller enabled. The user is responsible for supplying a switch, which is controllable by the control processor, to enable or disable the analog loop back mode. The receiver descrambler is set as the inverse of the transmitter scrambler so that the receiver detects correct bits.

If the modem is configured in the digital loop back mode, the transmitter clock is locked to the receiver clock and the received bits are used as the transmitter input.

**3.10 - Power-on Initialization**

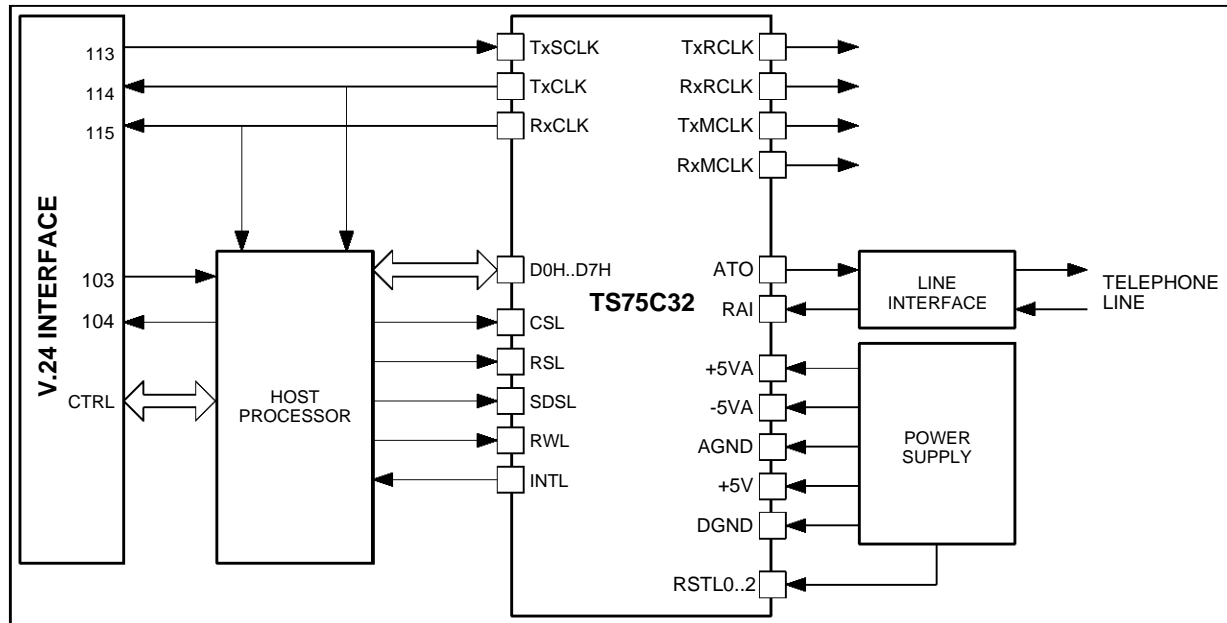
When the power is turned on, the transmitter interface sets the output signal attenuation to infinite. This avoids undesirable signal transmission on the telephone line (see ref 5 of Appendix D). The gain of the AGC in the receive interface is set at the lowest level to avoid signal clipping during the initial handshake. The clock generator is programmed to generate all the necessary clocks for the 9600bps mode. The clocks include the 7200Hz sampling clock, the 2400Hz baud rate clocks and the 9600bps bit rate clocks. The transmit clocks are free running when the TxSCLK pin is tied to a fixed logic level. Otherwise, the transmit bit clock is synchronized to the frequency present at the TxSCLK pin. DSP 1 is configured properly to receive commands from the control processor.

**4 - MODEM INTERFACE (Figure 8)**

**4.1 - Analog Interface**

The transmit signal at the tip and ring is programmable over a 22dB dynamic range by 2dB steps in TS68950. The signal level can be further scaled to any value by setting a scaling factor in the DSP. The nominal Transmit level, at the ATO pin is -5.7dBm.

**Figure 8 : Functional Interconnect Diagram**



75C32-16.EPS

## FUNCTIONAL DESCRIPTION (continued)

### 4.2 - Digital Interface

The DSP and control processor interface complies with the system bus interface of the ST18930. The interface to the control processor is managed by DSP 1 as shown in Figure 5. The DSP signals which are presented to the interface, and a brief definition of the signals are tabulated in Table 1.

**Table 1 :** Digital Interface Signals

Interface Signals	Signal Definition
D0H	Data Bus (LSB)
D1H	Data Bus
D2H	Data Bus
D3H	Data Bus
D4H	Data Bus
D5H	Data Bus
D6H	Data Bus
D7H	Data Bus (MSB)
RWL	Write Signal
DSL	Data Strobe
INTL	Mailbox Handshake
CSL	DSP Select
RSL	Register Select
TxRCLK	Transmit Baud Rate Clock
RxRCLK	Receive Baud Rate Clock
TxCLK	Transmit Bit Rate Clock
RxCLK	Receive Bit Rate Clock
TxMCLK	Transmit Multiplex Clock
RxMCLK	Receive Multiplex Clock
TxSCLK	Transmit Terminal Clock

All information exchanges across this interface conform to the three byte mailbox structure (see ref 4 of Appendix D) and protocol of the DSP. As may be seen in the table, the DSP generates a control signal, INTL, which defines the mailbox handshake operation.

### 4.3 - Control Processor/DSP Interface

As seen by the software in the user provided control processor, DSP 1 is a synchronous machine. It requires the attention of the control processor at regular intervals in order to perform properly. Any failure of the control processor to interact with the modem engine in a timely manner will result in reduced performance or improper operation.

Each interaction begins when the control processor sends a three byte command to the mailbox. Once the command has been written to the mailbox, the ownership of the mailbox is relinquished by the control processor. Upon acquisition of the mailbox, DSP 1 reads the command bytes and then sends a three byte response to the mailbox. Then, DSP 1 relinquishes the ownership of the mailbox back to the control processor. The received command is then decoded and the embedded data and/or operational parameters are extracted and acted upon

as appropriate. The modem status information will be collected for the next mailbox exchange. The control processor handles the returned information as soon as it regains the ownership of the mailbox. Because the control processor owns the mailbox initially, it may store a command at any time before it is required by DSP 1. After this, the mailbox becomes available to DSP1 and can be read by it when required.

### 4.4 - Mailbox Description

The mailbox located internally to the DSP contains 3-byte input (RIN) and 3-byte output (ROUT) shift registers. The DSP has an internal flag RDYOIN which indicates whether the DSP (RDYOIN = 0) or control processor (RDYOIN = 1) has access to the mailbox. The DSP can relinquish its accessibility to the mailbox by setting RDYOIN but it can no longer regain access to the mailbox as RDYOIN is reset only after the control processor relinquishes its accessibility to the mailbox. The access protocol and system bus transfers are controlled by an internal I/O sequencer within the DSP described as follows :

1. The mailbox is made available to the control processor by the DSP program which sets RDYOIN flag to 1. This action will cause INTL mailbox handshake signal to switch to the active (low) state.
2. The control processor detects INTL active and dummy reads the mailbox by forcing DSP Select (CSL) and Register Select (RSL) low along with write signal (RWL) high. The activated Data Strobe signal (DSL = 0) validates the above signals.
3. The DSP detects the dummy read of its mailbox via the control signals mentioned in 2 and negates INTL mailbox handshake signal within 800ns.
4. The control processor detects the negation of INTL indicating that the DSP mailbox is available for data transfers. The control processor writes three 8-bit bytes and/or reads three 8-bit bytes in the mailbox shift registers RIN, ROUT respectively.
5. The exchange protocol described above is terminated by the control processor performing a dummy read of the mailbox as in 2 but with RSL in the high state.
6. The RDYOIN flag within the DSP is cleared to 0 by the dummy read of the mailbox in step 5 and the DSP now has access to RIN and ROUT registers within the mailbox.

## USER INTERFACE - COMMAND SET

The command set has the following attractive features :

- User friendly with easy to remember mnemonics
- Allows straightforward expansion with new commands to suit specific customization requirements
- Fully compatible with other SGS-THOMSON DSP-based modem products.

The command set has been designed to provide the necessary functional control of the TS75C32. Each command falls into one of several groups, based on function and the presence or absence of parameters. The length of the OP code varies with instruction type, but in all cases, a command consists of three bytes.

The commands which pass parameters or data to DSP 1 have a short OP code format. Byte 0 forms the OP code portion of the command. Bytes 1 and 2 are data and/or parameters associated with each OP code. The meaning of the last two bytes is dependent on the specific instruction.

Other instructions command the TS75C32 to perform certain specific tasks. These do not pass parameters or data to the TS75C32. These commands have an OP code which is a full 24 bits in length.

The command set of the TS75C32 is summarized below. The descriptions are of the form :

**MNEMONIC (OPCODE) : DESCRIPTION**

For detailed information and data format specifics of each command, please refer to appendix A.

### 1 - COMMAND SUMMARY

#### 1.1 - Operational Control Commands

**FREZ** (14): Freeze adaptive processes. Freeze the adaptive processes as specified by the data in bits 0 and 1 of byte 1. Bit 0 of byte 1 controls the adaptive equalizer. Freeze the equalizer if bit 0 of byte 1 is 1. A 0 in this bit will unfreeze the equalizer. Echo canceller adaptation is controlled by bit 1 of byte 1. If bit 1 is 1, the echo canceller adaptation is frozen. The echo canceller adaptation is unfrozen by a 0 in bit 1.

**HSHK** (040000) : Handshake. Begin the handshake sequence. The V.32 modem engine carries out all the steps defined in the CCITT recommendation. The status reported to the control processor will indicate the success or failure of the process and its progress.

**INIT** (0600C0) : Initialize. Initialize the V.32 modem engine. Set all parameters to default values and wait for commands for the control processor.

**NOP** (000000) : No Operation. No new operation is commanded. The state of the V.32 engine remains unaltered and a previously invoked multi-baud command (such as HSHK) continues.

**RTRA** (050000) : Retrain. Start sending the retrain sequence as defined in the CCITT recommendation.

**SETGN** (02) : Set Gain. This command sets a global gain factor, which will be multiplied by all transmit samples before being sent to the TS68950. Bytes 1 and 2 store the gain factor.

#### 1.2 - Data Communications Commands

**XMIT** (03) : Transmit data. Transmit data to far end modem. The data is provided in byte 1 of the command, where the least significant bit is the first bit to be transmitted. The third byte of the command must be provided, but is not used. Hence, any value may be supplied.

**XMITI** (01) : Transmit data and Initiate additional cycle. Transmit data and inform the DSP to accept another command at the next transmit baud. If the next command requires an answer from DSP 1, the control processor has to keep issuing this command followed by a command which does not require an answer until the answer has been received.

#### 1.3 - Memory Manipulation Commands

**SPAC** (13) : Store Parameter And Count. Store parameter in addressed memory and increment the pointer. This command passes data in bytes 1 and 2, least significant byte in byte 1. It is used to write an arbitrary 16-bit value into the writable memory location currently specified by the Memory Address Register. The contents of the Memory Address Register are incremented by 1 at the completion of this command.

**SPAM** (12) : Store parameter in Addressed Memory. This command passes data in bytes 1 and 2, least significant byte in byte 1. It is used to write an arbitrary 16-bit value into the writable memory location currently specified by the Memory Address Register.

**WARP** (10) : Write Address and Return Parameter. This command allows the controller to read any of the XRAM, YRAM, ERAM or CROM (DSP internal memory areas) of any of the three modem DSPs without interrupting the processors. The address to the V.32 modem engine is provided in bytes 1 and 2 of the command (least significant byte first). DSP 1 stores the address in the Memory Address Register and returns the contents of the addressed location.



## USER INTERFACE - COMMAND SET (continued)

**WARPX (11)** : Write Address and Return Parameter Complex. The address to the V.32 modem engine is provided in bytes 1 and 2 of the command (least significant byte first). DSP 1 stores the address in the Memory Address Register. The most significant bytes of the real and imaginary parts of a complex number are returned. The 8 most significant bits of the data addressed by the Memory Address Register are returned to the control processor through byte 1. Byte 2 stores the 8 most significant bits of the data at the location immediately higher. The Memory Address Register retains the address provided. (i.e. it is not incremented.)

### 1.4 - Configuration Control Commands

**CV32 (20)** : Configure modem for V.32. Configure the modem as Originate / Answer, 9600/4800, Viterbi / No-Viterbi, Analog Loopback, Digital Loopback.

**CFSK (1D)** : Configure modem for FSK modes of operation (V.23/V.21/Bell103).

**CV22B (1E)** : Configure modem for V.22Bis/V.22/Bell212A modes.

### 1.5 - MAFE Manipulation Commands

**CMAFE (07)** : Configure MAFE. The following two bytes of this command are written directly to the MAFE chip set (TS68950/1/2). This allows the control processor to configure parameters, such as the transmit level, the receiver analog front end, and the transmit and receive clocks.

**RRR1 (080000)** : Read Register 1. Causes the TS75C32 Engine to read and immediately return the 12 bit contents of the MAFE register RR1.

**RRR2 (090000)** : Read Register 2. Causes the TS75C32 to read and immediately return the 12 bit contents of the MAFE register RR2.

**WTR1 (0A)** : Write Register 1. Causes the TS75C32 to write the supplied data to the MAFE register TR1.

**WTR2 (0B)** : Write Register 2. Causes the TS75C32 to write the supplied data to the MAFE register TR2.

### 1.6 - Tone Select Commands

**TONE (0C)** : Select Tone. Program the tone generator(s) for the desired tone(s). Examples include :

- **ANSWR (0C1000)** : Program the tone generator for the 2100Hz answer tone.
- **DTMF** (see appendix) : Program the tone generators for the tone pair which forms the specified DTMF digit.

This command selects the tones to be transmitted, but does not enable the tone generators. To transmit the tones, the tone control commands must be issued.

### 1.7 - Tone Control Commands

**DEFT1 (0E)** : Define Tone 1. Define tone 1 as specified by the parameter provided. The two data bytes following the opcode are used to program, but not enable, tone generator 1. The data for the tone is represented as a phase offset per sample. Byte 1 stores the least significant byte of the phase increment.

**DEFT2 (0F)** : Define Tone 2. Define tone 2 as specified by the parameter provided. The two data bytes following the opcode are used to program, but not enable, tone generator 2. The data for the tone is represented as a phase offset per sample. Byte 1 stores the least significant byte of the phase increment.

**SLNT (0D0000)** : Silence the tone generators. Discontinue tone transmissions by disabling the tone generators.

**TGEN (0D)** : Tone Generator control. Enable or disable tone generator 1 and tone generator 2 according to parameter provided. If both tone generators are enabled, the level of tone 2 is 2dB higher than that of tone 1.

## 2 - STATUS REPORTING

Whenever DSP 1 owns the mailbox, it transmits the modem status to the control processor. The status consists of three bytes of information which are stored by DSP 1 in its ROUT register for access by the control processor. These three bytes may consist of received bits and modem status or they may contain the answers to the previous command, such as WARP and RRR1/2.

Data bits have higher priority than the answer to the previous command. If both data byte and command answer are ready to be sent, the data will be sent.

Byte 0 contains status flags. Refer to appendix B for the detailed format of the status response. The four most significant bits, F00, F01, F10 and F11, indicate various conditions during the call establishment, handshaking and the data modes. They have different meanings in different modes. The flag DAV1 and DAV2 are used to indicate the type of information contained in bytes 1 and 2. Bit H is used to indicate the condition of the handshake and bit 107 informs the control processor whether the 107 flag has to be set.

**USER INTERFACE - COMMAND SET (continued)**

**DAV1 and DAV2.** If both DAV1 and DAV2 are set to 1, bytes 1 and 2 contain the data in response to the previous command. Refer to the relevant commands in appendix A to get the detailed information on the interpretation of the data in bytes 1 and 2. Otherwise, they contain either the received data bits or the handshake detection status or both.

If both bits are set to 0, both byte 1 and byte 2 contain the data bits, where the bits in byte 1 are received earlier in time. The least significant bit is the first bit received. The data bits are stored in byte 1 and the modem status is stored in byte 2 when DAV2 is 1 and DAV1 is 0. When DAV1 is 1 and DAV2 is 0, the control processor should ignore the data in byte 1 and get the detection status from byte 2.

During handshake operations the TS75C32 reports the detection status regularly. When the rate sequence is received, it will be transferred in byte 1 of the response. Each bit in byte 2 indicates the detection of a specific event in the training sequence. It has different meanings for call and answer modems. For detailed information, refer to appendix B. During the data mode, byte 2 is always provided, but is used only when there are two bytes of data to transmit. This occurs occasionally when the receiver clock is running faster than the transmitter clock.

**F00-F11 bits.** During the call establishment operation, the V.32 Engine reports call progress tones through the F01 and F00 flags. F00 is set to 1 when the signal energy in frequency band 1 is above the threshold level. F01 is set to 1 when the signal energy in band 2 is above the threshold level. Detection of the 2100Hz answer tone is indicated by setting the F10 flag to a 1.

During handshake operations, all four bits are used to indicate the line condition and some detection

results. F00 is set to 0 if the line quality is good and 1 if it is bad. F01 is set to 1 if any segment in the training sequence is not detected within a time out. This bit can be used to indicate a non V.32 detection if either AA is not detected in the answer modem or the AC is not detected in the call modem. Both F00 and F01 are set to 1 when an illegal mode or a GSTN clear-down is received in the rate sequence.

The detection of the rate sequence is reported in the flags F11 and F10. When the modem is operating at 9600 bps without trellis coding, these bits are both set to 0. With trellis coding at 9600bps, F11 is set to 1 and F10 is cleared to 0. For 4800bps, 0 and 1 will be placed in F11 and F10, respectively. When both F11 and F10 are set to 1, the modem has negotiated with the far end modem and determined that the maximum negotiated operating speed is 2400bps.

During data mode, the perceived line quality is reported in the flags F01 and F00. The line conditions are reported as either good (code 00), poor (code 01), or terrible (code 10). The code 10 should be interpreted as a local modem retrain request. Upon receipt of this code, the controller can issue the RTRA command to begin the retrain procedure. The code 11 is used when the remote modem begins a retrain sequence. The control processor is then responsible for manipulating the appropriate data communications interface signals.

**H and 107 bits.** When the TS75C32 is commanded to perform the CCITT handshake sequence, the H bit will be set to 1 for the duration of the handshake operation. At the successful completion of the hand-shake operation the H flag will go to 0 and the control processor is then responsible for manipulating the appropriate data communications interface signals. e.g. 106 and 109. The 107 flag is set to a 1 to indicate that the controller should assert signal 107 on the data communications interface.

**3 - COMMAND LIST**

**Operational Control Commands**

Command Mnemonic	OP Code (HEX)	Description
uFzec	170000	Unfreeze Echo Canceller
Frezq	1B0000	Freeze the Equalizer Adaptation
Frezc	160000	Freeze the Echo Canceller Adaptation
uFzeq	1C0000	Unfreeze Equalizer
hshk	040000	Handshake with Other Modem
init	0600C0	Initialize Modem
jmp	06	Force Code Execution
nop	000000	No Operation
rtra	050000	Retrain
setgn	02	Set the Scaling Factor for the Transmitter

**USER INTERFACE - COMMAND SET** (continued)**Data Communication Commands**

Command Mnemonic	OP Code (HEX)	Description
xmit	03	Transmit Data
xmiti	01	Transmit Data and Initiate Additional Transfer

**Mafe Manipulation Commands**

Command Mnemonic	OP Code (HEX)	Description
cmafe	07	Configure MAFE Chipset
rrr1	080000	Read MAFE Reg RR1
rrr2	090000	Read MAFE Reg RR2
wtr1	0A	Write MAFE Reg TR1
wtr2	0B	Write MAFE Reg TR2

**Tone Select Commands**

Command Mnemonic	OP Code (HEX)	Description
answ	0C1000	Select 2100Hz Answer Tone
dtmf 0	0C0000	Select DTMF Digit 0
dtmf 1	0C0100	Select DTMF Digit 1
dtmf 2	0C0200	Select DTMF Digit 2
dtmf 3	0C0300	Select DTMF Digit 3
dtmf 4	0C0400	Select DTMF Digit 4
dtmf 5	0C0500	Select DTMF Digit 5
dtmf 6	0C0600	Select DTMF Digit 6
dtmf 7	0C0700	Select DTMF Digit 7
dtmf 8	0C0800	Select DTMF Digit 8
dtmf 9	0C0900	Select DTMF Digit 9
dtmf *	0C0E00	Select DTMF Digit *
dtmf #	0C0F00	Select DTMF Digit #
tone	0C	Select Tone (s)

**Configuration Control Commands**

Command Mnemonic	OP Code (HEX)	Description
cv32	20	Configure Modem for V.32
CFSK	1D	Configure Modem for FSK (V.23 / V.21 / Bell 103)
cv22B	1E	Configure Modem for V.22 / V.22bis / Bell 212A
cb21	26	Configure Modem for V.21
cb212	27	Configure Modem for Bell212
cb103	28	Configure Modem for Bell103

**Memory Manipulation Commands**

Command Mnemonic	OP Code (HEX)	Description
spac	13	Write MEM and Increment MEM Pointer
spam	12	Write MEM
warp	10	Write MEM Pointer & Read MEM
warpx	11	Write MEM Pointer & Read MEM & MEM + 1

**Tone Control Commands**

Command Mnemonic	OP Code (HEX)	Description
deft1	0E	Define Tone 1
deft2	0F	Define Tone 2
slnt	0D0000	Transmit no Tone
tgen 0	0D0000	Tone Generators Disabled
tgen 1	0D0100	Tone Generator 1 Enabled
tgen 2	0D0200	Tone Generator 2 Enabled
tgen 3	0D0300	Tone Generators 1 & 2 Enabled

**APPENDIX A : COMMAND SET DESCRIPTION**

**CMAFE** - Configure the TS68950/1/2 Components of the V.32 Engine

**INSTRUCTION TYPE**

MAFE manipulation command

**OPCODE**

07

**SYNOPSIS**

CMAFE address register code data

**DESCRIPTION**

CMAFE is used to directly manipulate the operating parameters of the TS68950/1/2 components of the V.32 Engine. This is a low level command which allows the controller to alter such things as the transmit level, transmit timing, receive timing, and receiver parameters, etc. The command consists of a single byte OPcode followed by a byte containing the address code for the desired register and a data byte for the addressed register. The data bytes will be transferred in the order received and interpreted by the addressed device. Refer to the data sheets of the TS68950, TS68951, and TS68952 for programming specifics.

**BYTE DEFINITION (OP CODE)**

0	0	0	0	0	1	1	1
---	---	---	---	---	---	---	---

**BYTE 1 DEFINITION**

R	R	R	0	0	0	0	0
---	---	---	---	---	---	---	---

REG CODE (Refer to TS68950 Data Sheet).

**BYTE 2 DEFINITION**

*	*	*	*	*	*	*	*
---	---	---	---	---	---	---	---

DATA BYTE (Refer to TS68950 Data Sheet)

**CFSK** - Configure for FSK Modes

**INSTRUCTION TYPE**

Configuration control command

**OPCODE**

1D

**SYNOPSIS**

CFSK al orig atn mode ll

**DESCRIPTION**

CFSK is used to select the FSK mode of operation.

**BYTE 0 DEFINITION (OP CODE)**

0	0	0	1	1	1	0	1
---	---	---	---	---	---	---	---

**BYTE 1 DEFINITION**

0	0	0	0	AL	MOD1	MOD0	ORIG
---	---	---	---	----	------	------	------

**BYTDEFINITION**

ALAnalog Loopback Enable

ORIGAnswer mode/Originate mode

**BYTE 2 DEFINITION**

ATN3	ATN2	ATN1	ATN0	0	0	LL	0
------	------	------	------	---	---	----	---

**BYTDEFINITION**

ATN3-0Transmit attenuation

**APPENDIX A : COMMAND SET DESCRIPTION (continued)**

**CV22B** - Configure for CCITT V.22bis Mode, CCITT V.22 and Bell 212A

**INSTRUCTION TYPE**

Configuration control command

**OPCODE**

1E

**SYNOPSIS**

CV22B al mode orig atn LL guard fallback

**DESCRIPTION**

CV22B is used to select the CCITT V.22Bis mode of operation. Select also, depending of Mode bits, the V.22, V.22 600bps and the Bell 212A.

**BYTE 0 DEFINITION (OP CODE)**

0	0	0	1	1	1	1	0
---	---	---	---	---	---	---	---

**BYTE 1 DEFINITION**

G1	G0	0	0	AL	MOD1	MOD0	ORIG
----	----	---	---	----	------	------	------

**BYTDEFINITION**

ALAnalog Loopback Enable

MOD1	MOD0	Selected Mode
0	0V.22Bis	2400bps

**BYTE 2 DEFINITION**

ATN3	ATN2	ATN1	ATN0	0	0	LL	FB
------	------	------	------	---	---	----	----

**BYTDEFINITION**

ATN3-0Transmit attenuation  
 FBFallback mode for V.22bis

**CV32** - Configure for V.32 Mode

**INSTRUCTION TYPE**

Configuration control command

**OPCODE**

20

**SYNOPSIS**

CV32 speed ec orig atn al fc

**DESCRIPTION**

CV32 is used to alter the operating parameters of the V.32 Engine. The passed parameters provide a two bit speed code which selects the desired baud rate. Another parameter explicitly turns on or off the echo canceller. If the V.32 Engine is to operate in the originate mode, the orig parameter must be set. When this parameter is not set, the V.32 Engine is configured as an answer mode device. The al parameter allows the user to select the analog loopback test conditions. The transmit attenuation level is selected by the atn parameter. etc.

**BYTE 0 DEFINITION (OP CODE)**

0	0	1	0	0	0	0	0
---	---	---	---	---	---	---	---

**BYTE 1 DEFINITION**

RSV	RSV	FC	EC	AL	SP1	SP0	ORIG
-----	-----	----	----	----	-----	-----	------

**Flag Bit Definition**

RSV - Reserved  
 FC 0/1 Do not/Do force cleardown  
 EC 0/1 Echo Canceller off/on  
 AL 0/1 Analog Loopback test disabled/enabled  
 ORIG 0/1 Answer mode / Originate mode

**SPEED CODE : SP1-0**

00 : 9600 bps  
 10 : 9600 bps treillis  
 01 : 4800 bps  
 11 : 2400 bps

**BYTE 2 DEFINITION**

ATN3	ATN2	ATN1	ATN0	0	0	LL	0
------	------	------	------	---	---	----	---

**Flag Bit Definition**

ATN3-0 Transmit attenuation  
 0 dB to 22 dB : codes 0000 to 1011  
 in 2 dB steps  
 Infinite : codes 1100 to 1111  
 RSV - Reserved

**APPENDIX A : COMMAND SET DESCRIPTION (continued)**

**DETF1** - Define Tone 1

**INSTRUCTION TYPE**  
Tone control command

**OPCODE**  
0E

**SYNOPSIS**  
DEFT tone descriptor

**DESCRIPTION**  
DEFT1 is a command which used to program tone generator 1. The 16 bit value provided is used as the phase offset per baud for the generator. The DEFT1 command does not enable the tone generator. See also TGEN.

**BYTE 0 DEFINITION (OP CODE)**

0	0	0	0	1	1	1	0
---	---	---	---	---	---	---	---

**BYTE 1 DEFINITION**

P7	P6	P5	P4	P3	P2	P1	P0
----	----	----	----	----	----	----	----

LOW BYTE OF DESCRIPTOR

**BYTE 2 DEFINITION**

P15	P14	P13	P12	P11	P10	P9	P8
-----	-----	-----	-----	-----	-----	----	----

HI BYTE OF DESCRIPTOR

**DETF2** - Define Tone 2

**INSTRUCTION TYPE**  
Tone control command

**OPCODE**  
0F

**SYNOPSIS**  
DEFT tone descriptor

**DESCRIPTION**  
DEFT2 is a command which used to program tone generator 2. The 16 bit value provided is used as the phase offset per baud for the generator. The DEFT2 command does not enable the tone generator. See also TGEN.

**BYTE 0 DEFINITION (OP CODE)**

0	0	0	0	1	1	1	1
---	---	---	---	---	---	---	---

**BYTE 1 DEFINITION**

P7	P6	P5	P4	P3	P2	P1	P0
----	----	----	----	----	----	----	----

LOW BYTE OF DESCRIPTOR

**BYTE 2 DEFINITION**

P15	P14	P13	P12	P11	P10	P9	P8
-----	-----	-----	-----	-----	-----	----	----

HI BYTE OF DESCRIPTOR

**APPENDIX A : COMMAND SET DESCRIPTION** (continued)

**FREZ** - Freeze the Equalizer or Echo Canceller Adaptation

**INSTRUCTION TYPE**

Operational control command

**OPCODES**

16/17/1B/1C

**SYNOPSIS**

FREZ freeze code

**DESCRIPTION**

FREZ causes the V.32 Engine to enable or disable the adaptation of the equalizer and / or the echo canceller, to the parameter provided.

FREZ includes four different opcodes, each one with a specific option :

- Freezc (16) : Freeze the echo canceller adaptation
- uFzecz (17) : Unfreeze the echo canceller
- Freezq (1B) : Freeze the equalizer adaptation
- uFzeq (1C) : Unfreeze the equalizer

**HSHK** - Begin Handshake Sequence

**INSTRUCTION TYPE**

Operational control command

**OPCODE**

040000

**SYNOPSIS**

HSHK EA

**DESCRIPTION**

HSHK is used to command the V.32 Engine to begin the handshake sequence processing. The progress of the handshake is reported to the control processor along with the data bits. For detailed information, refer to appendix B.

**BYTE 0 DEFINITION (OP CODE)**

0	0	0	0	0	1	0	0
---	---	---	---	---	---	---	---

**BYTE 1 DEFINITION (OP CODE)**

0	0	0	0	0	0	0	0
---	---	---	---	---	---	---	---

**BYTE 2 DEFINITION (OP CODE)**

0	0	0	0	0	0	0	0
---	---	---	---	---	---	---	---

EA : V.25bis

0 enable V.25bis generation/recognition

1 disable V.25bis

**INIT** - Initialize the V.32 Engine

**INSTRUCTION TYPE**

Operational control command

**OPCODE**

0600C0

**SYNOPSIS**

INIT

**DESCRIPTION**

INIT forces the V.32 Engine to reset all parameters to their default conditions and restart operations.

**BYTE 0 DEFINITION (OP CODE)**

0	0	0	0	0	1	1	0
---	---	---	---	---	---	---	---

**BYTE 1 DEFINITION (OP CODE)**

0	0	0	0	0	0	0	0
---	---	---	---	---	---	---	---

**BYTE 2 DEFINITION (OP CODE)**

1	1	0	0	0	0	0	0
---	---	---	---	---	---	---	---

**NOP** - No Operation is Specified

**INSTRUCTION TYPE**

Operational control command

**OPCODE**

000000

**SYNOPSIS**

NOP

**DESCRIPTION**

NOP is used when communications with the V.32 Engine are required but no action is desired.

**BYTE 0 DEFINITION (OP CODE)**

0	0	0	0	0	0	0	0
---	---	---	---	---	---	---	---

**BYTE 1 DEFINITION (OP CODE)**

0	0	0	0	0	0	0	0
---	---	---	---	---	---	---	---

**BYTE 2 DEFINITION (OP CODE)**

0	0	0	0	0	0	0	0
---	---	---	---	---	---	---	---

**APPENDIX A : COMMAND SET DESCRIPTION (continued)**

**RRR1** - Read MAFE Register RR1

**INSTRUCTION TYPE**

MAFE manipulation command

**OPCODE**

080000

**SYNOPSIS**

RRR1

**DESCRIPTION**

RRR1 causes the V.32 Engine to read the 12 bit contents of the MAFE chipset register RR1. The data is returned in a standard three byte format. The least significant data byte is returned in byte 1, followed by the most significant data byte. Byte 0 is the standard response format (refer to appendix B) with DAV1 and DAV2 bits set to 1. Consult the data sheet of the TS68951 for the specifics of the returned data.

**BYTE 0 DEFINITION (OP CODE)**

0	0	0	0	1	0	0	0
---	---	---	---	---	---	---	---

**BYTE 1 DEFINITION (OP CODE)**

0	0	0	0	0	0	0	0
---	---	---	---	---	---	---	---

**BYTE 2 DEFINITION (OP CODE)**

0	0	0	0	0	0	0	0
---	---	---	---	---	---	---	---

**RRR2** - Read MAFE Register RR2

**INSTRUCTION TYPE**

MAFE manipulation command

**OPCODE**

090000

**SYNOPSIS**

RRR2

**DESCRIPTION**

RRR2 causes the V.32 Engine to read the 12 bit contents of the MAFE chipset register RR2. The data is returned in a standard three byte format. The least significant data byte is returned in byte 1, followed by the most significant data byte. Byte 0 is the standard response format (refer to appendix B) with DAV1 and DAV2 bits set to 1. Consult the data sheet of the TS68951 for the specifics of the returned data.

**BYTE 0 DEFINITION (OP CODE)**

0	0	0	0	1	0	0	1
---	---	---	---	---	---	---	---

**BYTE 1 DEFINITION (OP CODE)**

0	0	0	0	0	0	0	0
---	---	---	---	---	---	---	---

**BYTE 2 DEFINITION (OP CODE)**

0	0	0	0	0	0	0	0
---	---	---	---	---	---	---	---



**APPENDIX A : COMMAND SET DESCRIPTION (continued)****RTRA** - Force a Retrain of the V.32 Engine**INSTRUCTION TYPE**

Operational control command

**OPCODE**

050000

**SYNOPSIS**

RTRA fall

**DESCRIPTION**

RTRA is used to force the V.32 Engine to initiate a retrain sequence on the channel.

**BYTE 0 DEFINITION (OP CODE)**

0	0	0	0	1	0	0	1
---	---	---	---	---	---	---	---

**BYTE 1 DEFINITION (OP CODE)**

0	0	0	0	0	0	0	0
---	---	---	---	---	---	---	---

**BYTE 2 DEFINITION (OP CODE)**

0	0	0	0	0	0	0	FALL
---	---	---	---	---	---	---	------

Fallback (V.22Bis only)

1 Fallback to 1200Bps

0 goes up to 2400Bps

**SETGN** - Set Global Gain Factor**INSTRUCTION TYPE**

Operational control command

**OPCODE**

02

**SYNOPSIS**

STEGN gain value

**DESCRIPTION**

SETGN is a command which used to scale the transmit samples. The 16 bit value provided is used as the multiplicative constant to be multiplied with each transmit sample.

**BYTE 0 DEFINITION (OP CODE)**

0	0	0	0	0	0	1	0
---	---	---	---	---	---	---	---

**BYTE 1 DEFINITION**

G7	G6	G5	G4	G3	G2	G1	G0
----	----	----	----	----	----	----	----

LOW BYTE OF GAIN VALUE

**BYTE 2 DEFINITION**

G15	G14	G13	G12	G11	G10	G9	G8
-----	-----	-----	-----	-----	-----	----	----

HI BYTE OF GAIN VALUE

**APPENDIX A : COMMAND SET DESCRIPTION (continued)**

**SLNT** - Disable Tone Generators

**INSTRUCTION TYPE**

Tone command

**OPCODE**

0D0000

**SYNOPSIS**

SLNT

**DESCRIPTION**

SLNT causes the V.32 Engine to disable the tone generators, thus stopping the tone output (i.e. send silence).

**BYTE 0 DEFINITION (OP CODE)**

0	0	0	0	1	1	0	1
---	---	---	---	---	---	---	---

**BYTE 1 DEFINITION**

0	0	0	0	0	0	0	0
---	---	---	---	---	---	---	---

**BYTE 2 DEFINITION (OP CODE)**

0	0	0	0	0	0	0	0
---	---	---	---	---	---	---	---

**SPAC** - Store Parameter and Count

**INSTRUCTION TYPE**

Memory manipulation command

**OPCODE**

13

**SYNOPSIS**

SPAC lo-byte hi-byte

**DESCRIPTION**

SPAC is a command which used to write an arbitrary 16 bit value into the writable memory location currently specified by the Memory Address Register. The content of the Memory Address Register is incremented by 1 at the completion of command execution. See also WARP.

**BYTE 0 DEFINITION (OP CODE)**

0	0	0	1	0	0	1	1
---	---	---	---	---	---	---	---

**BYTE 1 DEFINITION**

D7	D6	D5	D4	D3	D2	D1	D0
----	----	----	----	----	----	----	----

LOW BYTE OF DATA

**BYTE 2 DEFINITION**

D15	D14	D13	D12	D11	D10	D9	D8
-----	-----	-----	-----	-----	-----	----	----

HI BYTE OF DATA

**APPENDIX A : COMMAND SET DESCRIPTION (continued)**

**SPAM** - Store Parameter in Addressed Memory

**INSTRUCTION TYPE**

Memory manipulation command

**OPCODE**

12

**SYNOPSIS**

SPAM lo-byte hi-byte

**DESCRIPTION**

SPAM is a command which used to write an arbitrary 16 bit value into the writable memory location currently specified by the Memory Address Register. See also WARP.

**BYTE 0 DEFINITION (OP CODE)**

0	0	0	1	0	0	1	0
---	---	---	---	---	---	---	---

**BYTE 1 DEFINITION**

D7	D6	D5	D4	D3	D2	D1	D0
----	----	----	----	----	----	----	----

LOW BYTE OF DATA

**BYTE 2 DEFINITION**

D15	D14	D13	D12	D11	D10	D9	D8
-----	-----	-----	-----	-----	-----	----	----

HI BYTE OF DATA

**TGEN** - Enable and Disable Tone Generators

**INSTRUCTION TYPE**

Tone control command

**OPCODE**

0D

**SYNOPSIS**

TGEN tg code

**DESCRIPTION**

TGEN causes the V.32 Engine to enable or disable tone generator 1 and tone generator 2, according to the parameter provided.

**BYTE 0 DEFINITION (OP CODE)**

0	0	0	0	1	1	0	1
---	---	---	---	---	---	---	---

**BYTE 1 DEFINITION (TONE CODE)**

0	0	0	0	0	0	TGC2	TGC1
---	---	---	---	---	---	------	------

TG CODE TGC2-1	TONE GEN 1	TONE GEN 2
00	Disabled	Disabled
01	Enabled	Disabled
10	Disabled	Enabled
11	Enabled	Enabled

**APPENDIX A : COMMAND SET DESCRIPTION (continued)**

**TONE** - Select and Transmit Tone(s)

**INSTRUCTION TYPE**

Tone select and command

**OPCODE**

0C

**SYNOPSIS**

TONE tone code

**DESCRIPTION**

TONE causes the V.32 Engine to program the tone generators for the specified tone or tones. The tones are defined by the tone code parameter passed in the second byte of the command. See also tonetab for the predefined single and double tones, and the commands DEFT and TGEN for user definable tones and tone generator control.

**BYTE 0 DEFINITION (OP CODE)**

0	0	0	0	1	1	0	0
---	---	---	---	---	---	---	---

**BYTE 1 DEFINITION (TONE CODE)**

T7	T6	T5	T4	T3	T2	T1	T0
----	----	----	----	----	----	----	----

**BYTE 2 DEFINITION (OP CODE)**

0	0	0	0	0	0	0	0
---	---	---	---	---	---	---	---

**HI BYTE OF DATA**

Tone Code	Tone Parameters
0	DTMF 0 (941 & 1336Hz)
1	DTMF 1 (697 & 1209Hz)
2	DTMF 2 (697 & 1336Hz)
3	DTMF 3 (697 & 1477Hz)
4	DTMF 4 (770 & 1209Hz)
5	DTMF 5 (770 & 1336Hz)
6	DTMF 6 (770 & 1477Hz)
7	DTMF 7 (852 & 1209Hz)
8	DTMF 8 (852 & 1336Hz)
9	DTMF 9 (852 & 1477Hz)
A	(697 & 1633Hz)
B	(770 & 1633Hz)
C	(852 & 1633Hz)
D	(941 & 1633Hz)
E	DTMF * (941 & 1209Hz)
F	DTMF # (941 & 1477Hz)
10	Answer tone (2100Hz)

**APPENDIX A : COMMAND SET DESCRIPTION (continued)**

**WARP** - Write Address & Return Parameter

**INSTRUCTION TYPE**

Memory manipulation command

**OPCODE**

10

**SYNOPSIS**

WARP address

**DESCRIPTION**

WARP is a command which is used to write the Memory Address Register of the V.32 Engine. The V.32 Engine responds with the contents of the addressed location. The data is returned in a standard three byte transfer. The least significant data byte is returned in the byte 1, followed by the most significant data byte. Byte 0 is the standard response format (refer to appendix B) with DAV1 and DAV2 bits set to 1.

**BYTE 0 DEFINITION (OP CODE)**

0	0	0	1	0	0	0	0
---	---	---	---	---	---	---	---

**BYTE 1 DEFINITION**

A7	A6	A5	A4	A3	A2	A1	A0
----	----	----	----	----	----	----	----

LOW BYTE OF DATA

**BYTE 2 DEFINITION**

P1	P0	M1	M0	A11	A10	A9	A8
----	----	----	----	-----	-----	----	----

PROC CODE P1-0	MEM CODE M1-0	ADDRESS HI A11-A8
00 : Master	00 : XRAM	
10 : Receiver	01 : YRAM	
01 : Echo Cancellor	10 : EMEM	
	11 : CROM	

**WARPX** - Write Address & Return Parameter Complex

**INSTRUCTION TYPE**

Memory manipulation command

**OPCODE**

11

**SYNOPSIS**

WARPX address

**DESCRIPTION**

WARPX is a command which is used to write the Memory Address Register of the V.32 Engine. The V.32 Engine responds with the contents of the most significant bytes of the addressed location and the addressed location +1. The data is returned in a standard three byte transfer. Byte 0 is the standard response format (refer to appendix B) with DAV1 and DAV2 bits set to 1. Byte 1 is used to return the 8 most significant bits contained in the addressed location. The 8 most significant bits of the addressed location +1 are returned in byte 2.

**BYTE 0 DEFINITION (OP CODE)**

0	0	0	1	0	0	0	0
---	---	---	---	---	---	---	---

**BYTE 1 DEFINITION**

A7	A6	A5	A4	A3	A2	A1	A0
----	----	----	----	----	----	----	----

LOW BYTE OF DATA

**BYTE 2 DEFINITION**

P1	P0	M1	M0	A11	A10	A9	A8
----	----	----	----	-----	-----	----	----

PROC CODE P1-0	MEM CODE M1-0	ADDRESS HI A11-A8
00 : Master	00 : XRAM	
10 : Receiver	01 : YRAM	
01 : Echo Cancellor	10 : EMEM	
	11 : CROM	

**APPENDIX A : COMMAND SET DESCRIPTION (continued)**

**WTR1** - Write MAFE Register TR1

**INSTRUCTION TYPE**

MAFE manipulation command

**OPCODE**

0A

**SYNOPSIS**

WTR1

**DESCRIPTION**

WTR1 causes the V.32 Engine to take the two supplied data bytes and write them in sequence to the MAFE chipset register TR1.

**BYTE 0 DEFINITION (OP CODE)**

0	0	0	0	1	0	1	0
---	---	---	---	---	---	---	---

**BYTE 1 DEFINITION (DATA)**

D3	D2	D1	D0	0	0	0	0
----	----	----	----	---	---	---	---

LOW BYTE OF DATA

**BYTE 2 DEFINITION (DATA)**

D11	D10	D9	D8	D7	D6	D5	D4
-----	-----	----	----	----	----	----	----

**WTR2** - Write MAFE Register TR2

**INSTRUCTION TYPE**

MAFE manipulation command

**OPCODE**

0B

**SYNOPSIS**

WTR2

**DESCRIPTION**

WTR2 causes the V.32 Engine to take the two supplied data bytes and write them in sequence to the MAFE chipset register TR2.

**BYTE 0 DEFINITION (OP CODE)**

0	0	0	0	1	0	1	1
---	---	---	---	---	---	---	---

**BYTE 1 DEFINITION (DATA)**

D3	D2	D1	D0	0	0	0	0
----	----	----	----	---	---	---	---

LOW BYTE OF DATA

**BYTE 2 DEFINITION (DATA)**

D11	D10	D9	D8	D7	D6	D5	D4
-----	-----	----	----	----	----	----	----

**APPENDIX A : COMMAND SET DESCRIPTION (continued)****XMIT** - Transmit Data to Other Modem**INSTRUCTION TYPE**

Data communications command

**OPCODE**

03

**SYNOPSIS**

XMIT data

**DESCRIPTION**

XMIT is used to command the V.32 Engine to send data. The OP code for the xmit command is a single byte. The data bits to be transmitted are stored in the second byte, where D0 is the first bit to be transmitted.

**BYTE 0 DEFINITION (OP CODE)**

0	0	0	0	0	0	0	1
---	---	---	---	---	---	---	---

**BYTE 1 DEFINITION**

D7	D6	D5	D4	D3	D2	D1	D0
----	----	----	----	----	----	----	----

D0-D7 DATA BITS

**BYTE 2 DEFINITION**

0	0	0	0	0	0	0	0
---	---	---	---	---	---	---	---

**XMITI** - Transmit Data to Other Modem and Initiate Additional Cycle**INSTRUCTION TYPE**

Data communications command

**OPCODE**

01

**SYNOPSIS**

XMIT data

**DESCRIPTION**

XMIT is used to command the V.32 Engine to send data. The OP code for the xmit command is a single byte. The data bits to be transmitted are stored in the second byte, where D0 is the first bit to be transmitted.

**BYTE 0 DEFINITION (OP CODE)**

0	0	0	0	0	0	1	1
---	---	---	---	---	---	---	---

**BYTE 1 DEFINITION**

D7	D6	D5	D4	D3	D2	D1	D0
----	----	----	----	----	----	----	----

D0-D7 DATA BITS

**BYTE 2 DEFINITION**

0	0	0	0	0	0	0	0
---	---	---	---	---	---	---	---

**APPENDIX B : STATUS REPORTING DESCRIPTION**

**BYTE 0 DEFINITION**

F11	F10	F01	F00	DAV2	DAV1	H	CD
-----	-----	-----	-----	------	------	---	----

Flag Code	Call Establish	Handshake Operations	Data XFER Operations
F01-00			
00	no tones	line quality is good	line quality is good
01	Band 1 detected	line terrible (local retrain req.)	line quality is poor
10	Band 2 detected	time out	line terrible (local retrain req.)
11	Both bands detected	line clear-down (V.32 only)	remote retrain sequence detected
F11-10			
00	reserved	9600 bps no trellis or 2400bps	reserved
01	Answer tone detected	4800 bps or 1200bps	reserved
10	V.32 : AC detected	9600 bps trellis	reserved
11	reserved	2400 bps	reserved

DAV1	DAV2	Definition
0	0	Data is in byte 1 and 2.
0	1	Data is in byte 1 and status word in byte 2.
1	0	No data bits and status word is in byte 2.
1	1	Answer to the last command is in bytes 1 and 2.

FLAG	BIT	Definition
H	0/1	Handshake is not/is in progress
CD	0/1	Set circuit 107 off/on (V.32) Set circuit 109 on/off (V.22Bis)

**BYTE 1 DEFINITION**

RD7	RD6	RD5	RD4	RD3	RD2	RD1	RD0
-----	-----	-----	-----	-----	-----	-----	-----

**BYTE 2 DEFINITION**

ST7	ST6	ST5	ST4	ST3	ST2	ST1	ST0
-----	-----	-----	-----	-----	-----	-----	-----

Flag Code	Handshake Operations				Data XFER Operations
F01-00	V.32		V.22Bis		
	Answer	Originate	Answer	Originate	
ST7	AA	AC	-	Unscr. 1	When DAV1, DAV2 bits are 0 an additional byte of receive data is available.
ST6	AA-CC	AC-CA	S1	S1	
ST5	silence	CA-AC	"1", 1.2 K	"1", 1.2 K	
ST4	S	S	"1", 2.4 K	"1", 2.4 K	
ST3	S/S	S/S	-	-	
ST2	R2	R1	-	-	
ST1	R3	-	-	-	
ST0	E	E	-	-	



## APPENDIX C

This appendix describes the interconnection between the different chips (in DIP package).

Signal Name	Chip/Pin	Description
-------------	----------	-------------

### SYSTEM INTERFACE

DOH..D7H	TS75C321/27..34	System Data Bus : connect to host processor
CSL	TS75C321/21	Chip Select : connect to host processor
RSL	TS75C321/22	Register Select : connect to host processor
DSL	TS75C321/20	Data Strobe : connect to host
RWL	TS75C321/19	Read/Write : connect to host
INTL	TS75C321/24	Interrupt Request : connect to host processor
RSTL1 RSTL2 RSTL0	TS75C321/23 TS75C322/23 TS75C320/23	Reset : connect to host processor Reset Reset

### CLOCK SIGNALS

TxRCLK	TS68952/16 TS75C321/26	Transmit Baud Clock
TxCCLK	TS68952/24 TS75C321/44 TS68950/19 TS68951/23	Transmit Conversion Clock
RxRCLK	TS68952/20 TS75C321/43 TS75C322/44	Receive Baud Clock
RxCCLK	TS68952/21 TS75C321/25 TS75C322/43 TS68951/22	Receive Conversion Clock
TxSCLK	TS68952/11	If not used must be grounded.
XTL1	TS68952/13	External Crystal Input : must be connected via a 5.76MHz crystal to XTL2
XTL2	TS68952/14	External Crystal Input
CLK	TS68952/15 TS68950/18 TS68951/21	Main Analog Clock : this output, in accordance with the XTL1/2 crystal, must be 1.4MHz ( $\pm 7\text{Hz}$ ).
25 MHz	TS75C320/15 TS75C321/15 TS75C322/15	Main Digital Clock : connect to a 25MHz oscillator
TxCCLK RxCCLK	TS68952/23 TS68952/22	Transmit Bit Clock Receive Bit Clock

### ANALOG SIGNALS

ATO	TS68950/15	Analog Transmit Output : connect to DAA
EEO	TS68950/16 TS68951/11	Analog Echo Cancelling Estimation
LEI	TS68951/17	Local Echo Input : must be grounded
RAI	TS68951/16	Receive Analog Input : connect to DAA
RFO	TS68951/13	This pin must be connected through a 1 $\mu\text{F}$ nonpolarised capacitor to AGC1 input.
AGC1	TS68951/12	
AGC2	TS68951/19	Connect to the analog ground through a 1 $\mu\text{F}$ nonpolarised capacitor
CD1	TS68951/18	Connect to the analog ground through a 1 $\mu\text{F}$ nonpolarised capacitor

**Caution :** The connection between EEO (TS68950/16) and EEI (TS68951/11) must be as close as possible to avoid parasitics on echo estimate signal

## TS75C32

### APPENDIX C (continued)

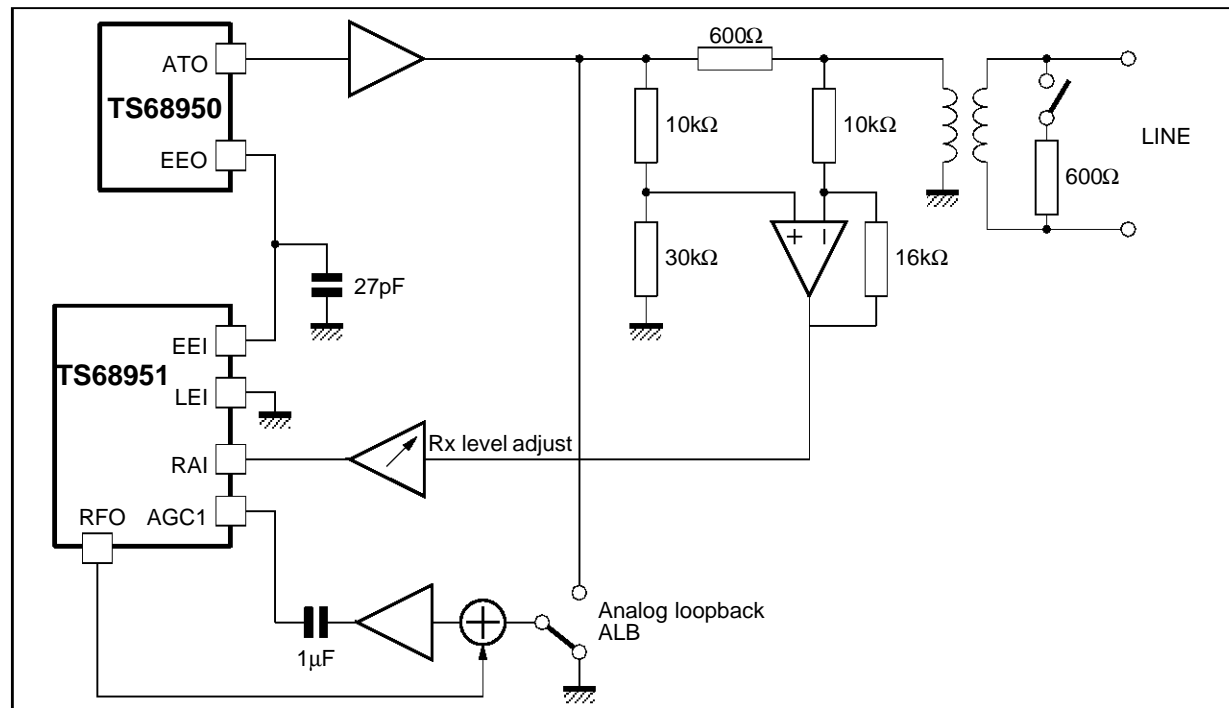
Signal Name	Chip/pin	Description
INTER DSP AND EXTERNAL MEMORY CONNECTION		
0D0..0D15	TS75C320/45..48,1..12 RAM0/IO0..IO15	Data Bus
1D8..1D15	TS75C321/5..12 - TS75C320/27..34 TS68950/20..24,1..3 RAM0/AD0..AD7	Data and Address Buses
1D0..1D7	TS75C321/45..48,1..4 - TS75C322/27..34 RAM2/AD0..AD7	Data and Address Buses
2D9..2D15	TS75C322/6..12 - TS68951/25..28,1..3 TS68952/25..28,1..3 RAM2/IO9..IO15	Data Bus
2D8	TS75C322/5 - TS68951/24 RAM2/IO8	Data Pin
2D0..2D7	TS75C322/45..48,1..4 RAM2/IO0..IO7	Data Bus
1A11	TS75C321/39 - TS75C320/21 TS75C322/21 - TS68950/7	Address Line
1A10	TS75C321/37 - TS68950/6	Address Line
1A9	TS75C321/36 - TS68950/9 - TS75C320/22	Address Line
1A8	TS75C321/35 - TS68950/8 - TS75C322/22	Address Line
1RWL	TS75C321/18 - TS75C320/19 TS75C322/19 - TS68950/5	Control Line
1DSL	TS75C321/17 - TS75C320/20 TS75C322/20 - TS68950/4	Control Line
0A8..0A11	TS75C320/35..37,39 RAM0/AD8..AD11	Address Line
0DSL	TS75C320/17 RAM0/CEL	Control Line
0RWL	TS75C320/18 RAM0/WEL	Control Line
2A8..2A11	TS75C322/35..37,39 - TS68951/8,9,6,7 TS68952/8,9,6,7 RAM2/A8..A10,CEL	Address Line
2DSL	TS75C322/17 - TS68951/4 - TS68952/4 RAM2/OEL	Control Line
2RWL	TS75C322/18 - TS68951/5 - TS68952/5 RAM2/WEL	Control Line
0IRQL	TS75C320/24 - TS75C321/42	Synchro Line
2IRQL	TS75C322/24 - TS75C321/41	Synchro Line

**Note :** RAM0 Refer to DSP0 4Kx16 External memory.  
RAM2 Refer to DSP2 2Kx16 External memory.  
Where : IO is bidirectional data bus  
AD is address line  
WEL is Write Enable (active low)  
CEL is Chip Select (active low)  
OEL is Output Enable (Optional)

APPENDIX C (continued)

Signal Name	Chip/Pin	Description
POWER SUPPLY AND MISCELLANEOUS		
+5VA	TS68951/20 - TS68950/17	Positive Analog Power Supply
-5VA	TS68951/14 - TS68950/12	Negative Analog Power Supply
AGND	TS68950/13 - TS68951/15	Analog Ground
V <sub>CC</sub>	TS75C320/38 - TS75C321/38 - TS75C322/38 - TS68952/17	Main Digital Power Supply
DGND	TS75C320/13 - TS75C321/13 - TS75C322/13 TS68950/10 - TS68951/10 - TS68952/12	Digital Ground Power Supply
xtal	TS75C320/14 - TS75C321/14 - TS75C322/14	Not Connected (must be left open)
Clkout	TS75C320/16 - TS75C321/16 - TS75C322/16	Not Connected (25MHz/4)
TO	TS68952/10	Not Connected (must be left open)
AGND	TS68950/14	Auxiliary Input
DGND	TS75C321/40 - TS75C320/40..44 - TS75C320/25..26 TS75C322/40..42 - TS75C322/25..26 - TS68950/11	Not Used

Figure 9 : Analog Path



75C32-17.EPS

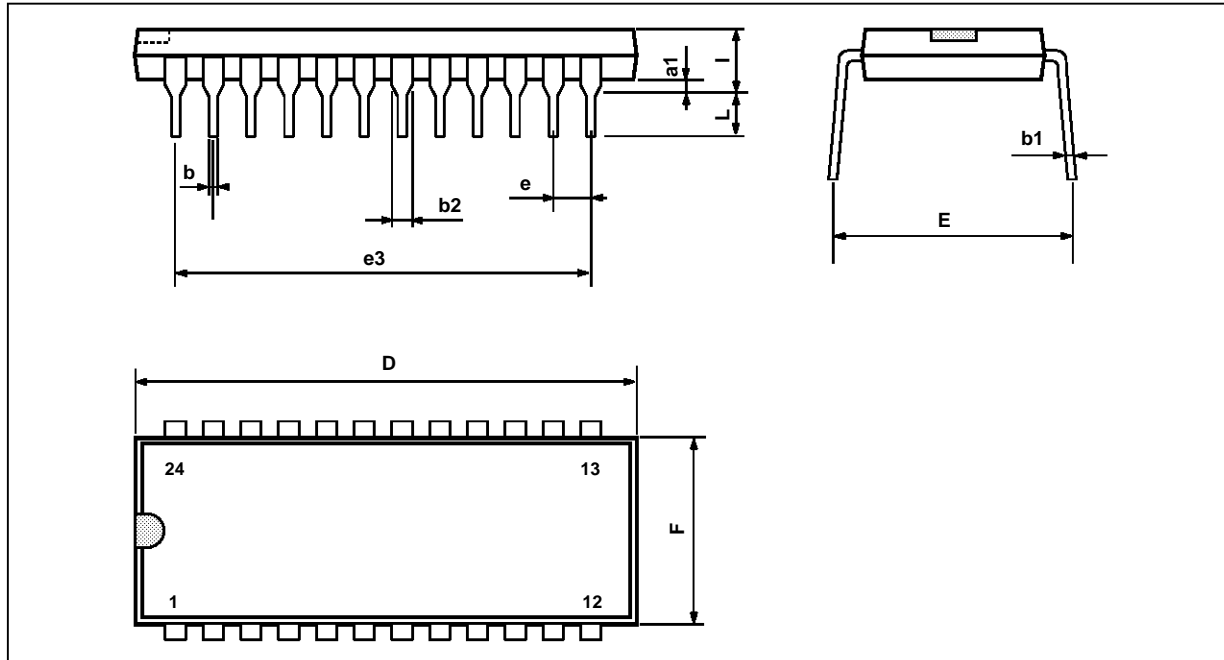
APPENDIX D : REFERENCES

1. CCITT recommendation V.32.
2. CCITT recommendation V.54.
3. Data sheet of the TS75320, V.32 modem echo canceller, SGS-THOMSON.
4. Data sheet of the TS68930, TS68931 programmable signal processor, SGS-THOMSON.
5. Data sheet of the TS68950 transmitter interface chip, SGS-THOMSON.
6. Data sheet of the TS68951 receiver interface chip, SGS-THOMSON.
7. Data sheet of the TS68952 clock generation chip, SGS-THOMSON.
8. Application guide : Using the TS75320 Echo canceller in V.32 modems, SGS-THOMSON.

# TS75C32

## PACKAGE MECHANICAL DATA

24 PINS - PLASTIC DIP

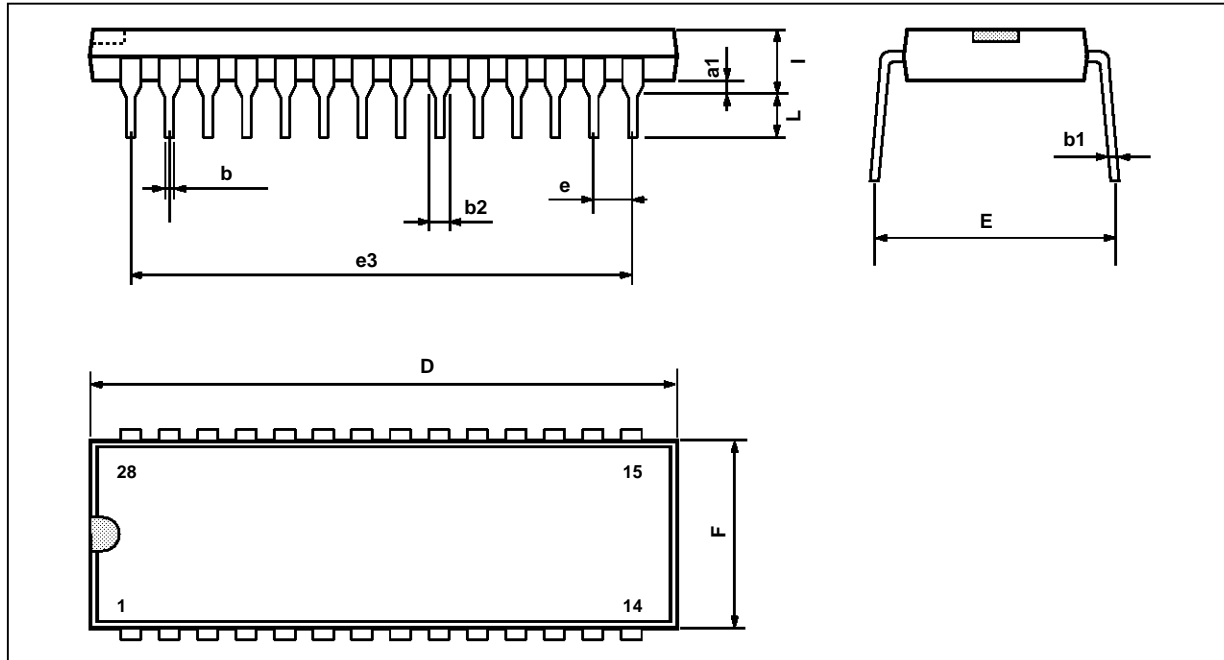


PM-DIP24EPS

Dimensions	Millimeters			Inches		
	Min.	Typ.	Max.	Min.	Typ.	Max.
a1		0.63			0.025	
b		0.45			0.018	
b1	0.23		0.31	0.009		0.012
b2		1.27			0.050	
D			32.2			1.268
E	15.2		16.68	0.598		0.657
e		2.54			0.100	
e3		27.94			1.100	
F			14.1			0.555
i		4.445			0.175	
L		3.3			0.130	

DIP24.TBL

**PACKAGE MECHANICAL DATA**  
28 PINS - PLASTIC DIP



PM-DIP28.EPS

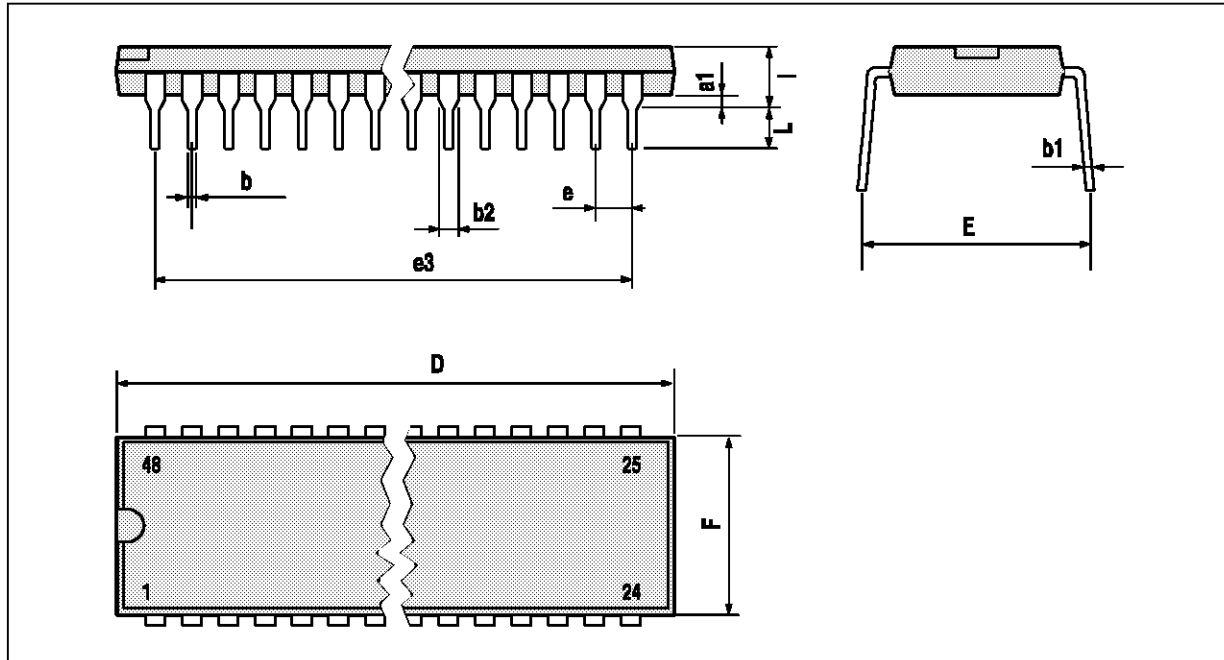
Dimensions	Millimeters			Inches		
	Min.	Typ.	Max.	Min.	Typ.	Max.
a1		0.63			0.025	
b		0.45			0.018	
b1	0.23		0.31	0.009		0.012
b2		1.27			0.050	
D			37.4			1.470
E	15.2		16.68	0.598		0.657
e		2.54			0.100	
e3		33.02			1.300	
F			14.1			0.555
i		4.445			0.175	
L		3.3			0.130	

DIP28.TBL

# TS75C32

## PACKAGE MECHANICAL DATA

48 PINS - PLASTIC DIP

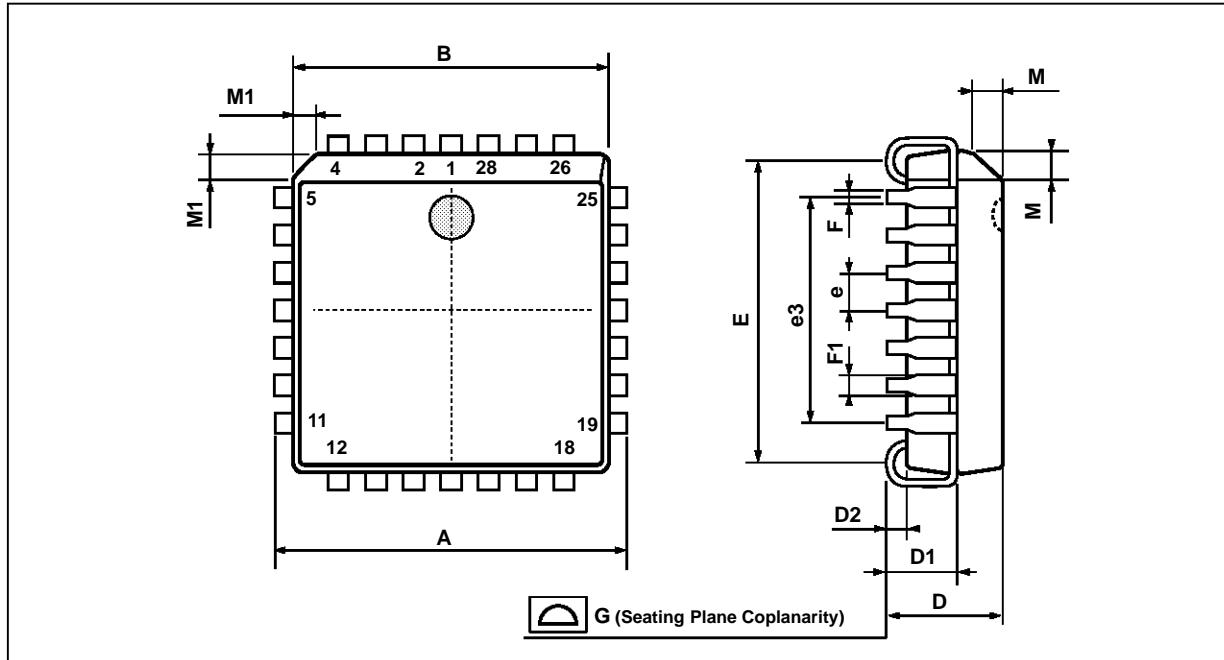


PM-DIP48.WMF

Dimensions	Millimeters			Inches		
	Min.	Typ.	Max.	Min.	Typ.	Max.
a1		0.63			0.025	
b		0.45			0.018	
b1	0.23		0.31	0.009		0.012
b2		1.27			0.050	
D			62.74			2.470
E	15.2		16.68	0.598		0.657
e		2.54			0.100	
e3		58.42			2.300	
F			14.1			0.555
i		4.445			0.175	
L		3.3			0.130	

DIP48.TBL

**PACKAGE MECHANICAL DATA**  
 28 PINS - PLASTIC CHIP CARRIER



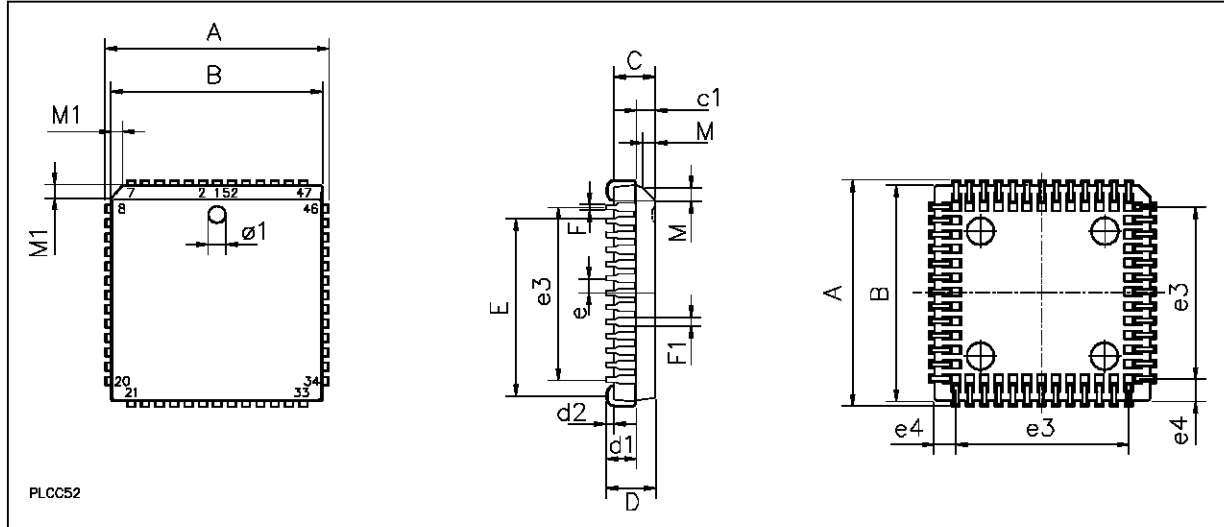
PMPLCC28.EPS

Dimensions	Millimeters			Inches		
	Min.	Typ.	Max.	Min.	Typ.	Max.
A	12.32		12.57	0.485		0.495
B	11.43		11.58	0.450		0.456
D	4.2		4.57	0.165		0.180
D1	2.29		3.04	0.090		0.120
D2	0.51			0.020		
E	9.91		10.92	0.390		0.430
e		1.27			0.050	
e3		7.62			0.300	
F		0.46			0.018	
F1		0.71			0.028	
G			0.101			0.004
M		1.24			0.049	
M1		1.143			0.045	

PLCC28.TBL

# TS75C32

## PACKAGE MECHANICAL DATA 52 PINS - PLASTIC CHIP CARRIER



Dimensions	Millimeters			Inches		
	Min.	Typ.	Max.	Min.	Typ.	Max.
A		4.20	5.08		0.165	0.20
A1		0.51			0.020	
A3		2.29	3.30		0.090	0.13
B		0.33	0.53		0.013	0.021
B1		0.66	0.81		0.026	0.032
C	0.25			0.01		
D		19.94	20.19		0.785	0.795
D1		19.05	19.20		0.750	0.756
D2		17.53	18.54		0.690	0.730
D3	15.24			0.60		
E		19.94	20.19		0.785	0.795
E1		19.05	19.20		0.750	0.756
E2		17.53	18.54		0.690	0.730
E3	15.24			0.60		
e	1.27			0.05		
L		0.64			0.025	
L1		1.53			0.060	
M		1.07	1.22		0.042	0.048
M1		1.07	1.42		0.042	0.056

Information furnished is believed to be accurate and reliable. However, SGS-THOMSON Microelectronics assumes no responsibility for the consequences of use of such information nor for any infringement of patents or other rights of third parties which may result from its use. No licence is granted by implication or otherwise under any patent or patent rights of SGS-THOMSON Microelectronics. Specifications mentioned in this publication are subject to change without notice. This publication supersedes and replaces all information previously supplied. SGS-THOMSON Microelectronics products are not authorized for use as critical components in life support devices or systems without express written approval of SGS-THOMSON Microelectronics.

© 1995 SGS-THOMSON Microelectronics - All Rights Reserved

Purchase of I<sup>2</sup>C Components of SGS-THOMSON Microelectronics, conveys a license under the Philips I<sup>2</sup>C Patent. Rights to use these components in a I<sup>2</sup>C system, is granted provided that the system conforms to the I<sup>2</sup>C Standard Specifications as defined by Philips.

SGS-THOMSON Microelectronics GROUP OF COMPANIES

Australia - Brazil - China - France - Germany - Hong Kong - Italy - Japan - Korea - Malaysia - Malta - Morocco  
The Netherlands - Singapore - Spain - Sweden - Switzerland - Taiwan - Thailand - United Kingdom - U.S.A.